

PNEUDRAULIC RIVETER

Read instructions thoroughly prior to operating the riveter. This riveter is designed for intermittent duty and maintenance work only.

OPERATING INSTRUCTIONS

The **PT-100-C** is a pneudraulic tool designed to set from 1/8" up to and including 1/4" diameter steel, stainless steel, aluminum and plastic rivets by changing only the nosepiece. The tool has a rated pull pressure of over 3,750 lbs. The **PT-100-C** riveter will operate effectively at any air pressure between 90 and 120 psi. (When setting 1/4" rivets or Magnalok® a minimum air pressure of 110 psi must be maintained). The maximum air pressure used with the tool should not exceed 120 psi. The **PT-100-C** utilizes totally different patented principles than any other riveter. The air pressure activates a reciprocating hydraulic pump which generates the force required to set the fastener.

WARNING: The hydraulic system is sealed and although there may be some visible residue around the trigger area, oil need not be added. If the tool should become damaged and leaks oil from the tool, IT SHOULD BE RETURNED TO AN AUTHORIZED SERVICE CENTER.



1206 East MacArthur Street • P.O. Box 1372 • Sonoma, California 95476
Phone: (707) 935-1170 • Toll Free: 800-344-2393 • Fax: (707) 935-1828
Email: sales@fsirivet.com • Website: www.fsirivet.com

How to Use the Tool

General Instructions

The **PT-100-C** pneudraulic riveter installs fasteners by a pull and release system. Squeezing the **Actuating Trigger "A"** only will actuate the tool. The tool must be actuated when installing fasteners and changing nose pieces. After installing the fastener or changing the nose piece the tool must be returned to its original position, this releases the pintail if a fastener was installed. To do this, point the tool downward and squeeze **Releasing Trigger "B"** only.

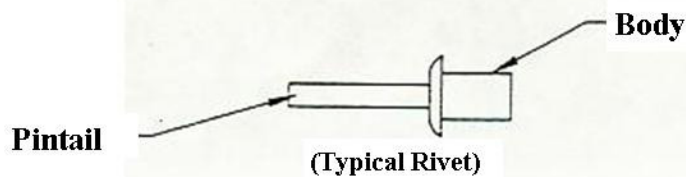

Nose Piece Installation: Select the proper nose piece for correct installation of fastener and function of the tool. To change the nose piece, remove the one in the tool by unscrewing it in a counterclockwise direction. Actuate tool until it is fully extended. There should be a gap of approximately 3/4" in between the reservoir shield and the tool body. Hand tighten the nose piece into the nose tube and release the tool by squeezing the **Releasing Trigger "B"** only. (see figure below).

Fastener Installation: Install correct nose piece on to tool. Insert pintail of rivet in to the nose piece. Position the rivet body in to work piece to be fastened. Hold the tool steady against the work piece and squeeze the **Actuating Trigger "A"** only, until fastener is installed and rivet pintail is broken.

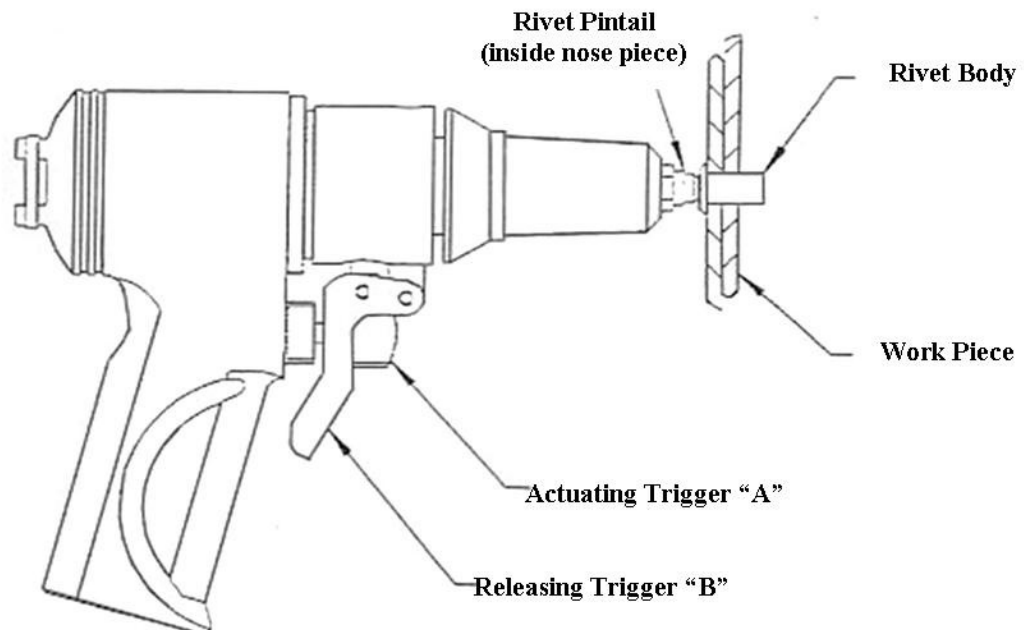

* The tool has a 5/8" work travel and will set most rivets in one cycle. If the tool reaches the end of its travel before the rivet breaks, the hydraulic system will lug down. DO NOT continue lugging the tool. Release the tool by squeezing the **Releasing Trigger "B"**, re-grip the rivet, squeeze the **Actuating Trigger "A"** and finish the installation.

Rivet Pintail Removal: Once the rivet has been installed the rivet pintail must be removed. This is done by squeezing the **Releasing Trigger "B"** only while pointing the tool downward. It is necessary to remove this pintail before attempting to install another rivet. (see figure 3)

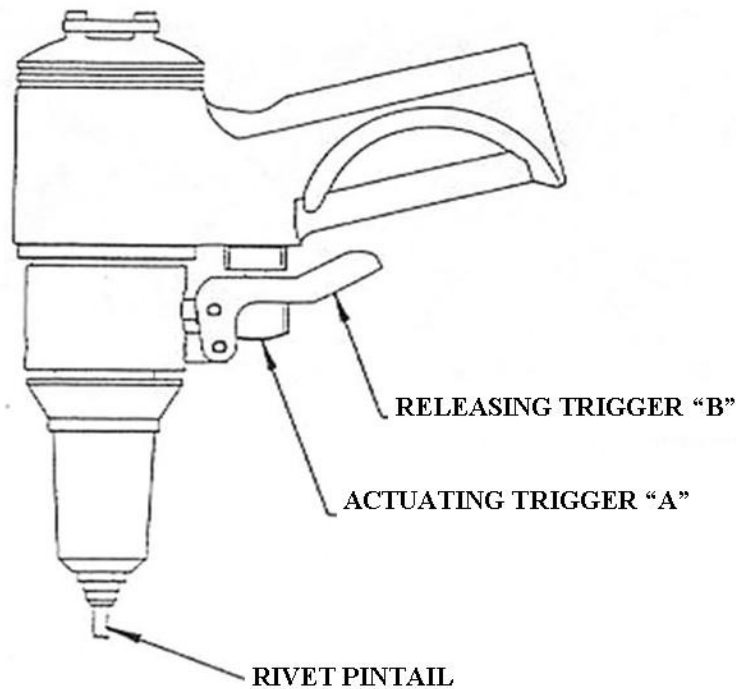
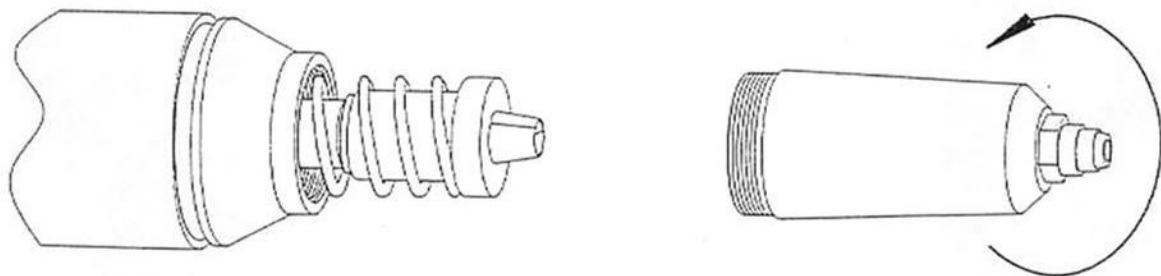

figure 3

NOTE: The jaws are installed at the factory and should only need to be removed for periodic inspection and cleaning.

1. To remove the **Jaws** unscrew the nose tube from the tool in a counterclockwise direction.



2. Remove the **Jaw Holder** by unscrewing it in a counterclockwise direction. Drop jaws out from spring side. Actuate tool by squeezing the **Actuating Trigger "A"** (see fig. 3 above) until the **Jaw Pusher** is fully extended. Stop as soon as the jaw pusher is in the extended position.

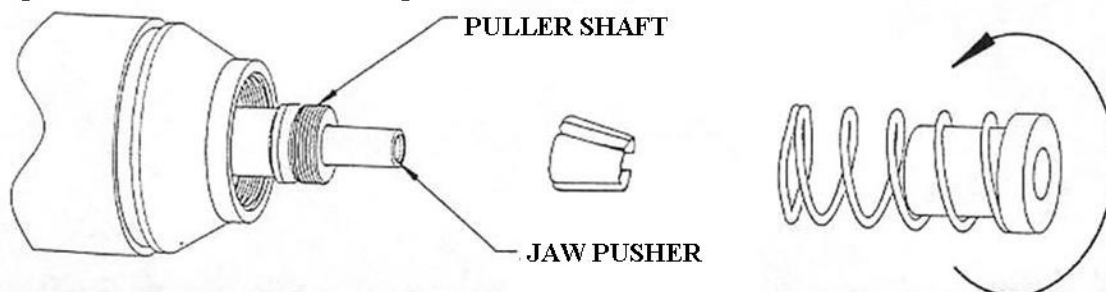

3. To replace **Jaws**, hold **Jaw Holder** large end down and at a slight angle.

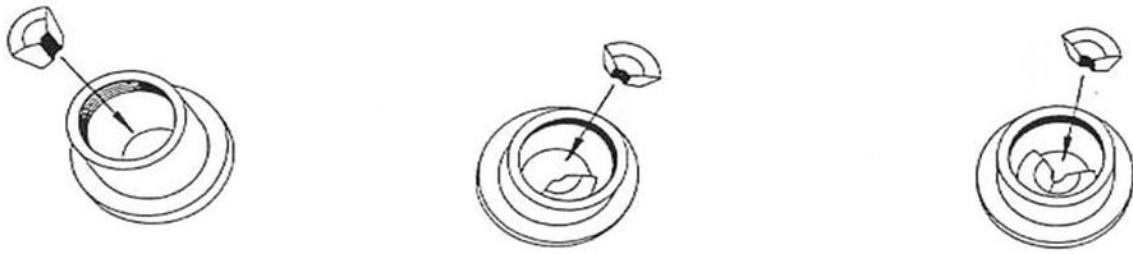

4. When the jaws are in place, insert **Jaw Holder** into **Spring**, being sure to keep large end of **Jaw Holder** pointing downward.

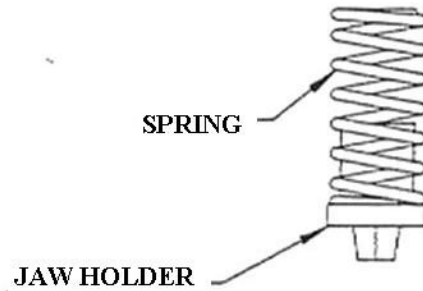

5. Hold tool with the puller shaft pointing down and **Jaw Pusher** fully extended. Screw the **Jaw Holder** on to the **Puller Shaft**. **HAND TIGHTEN ONLY.**

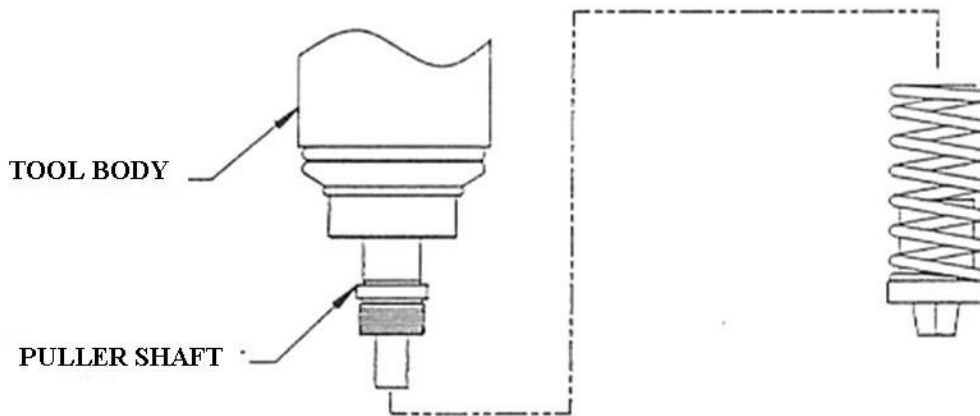

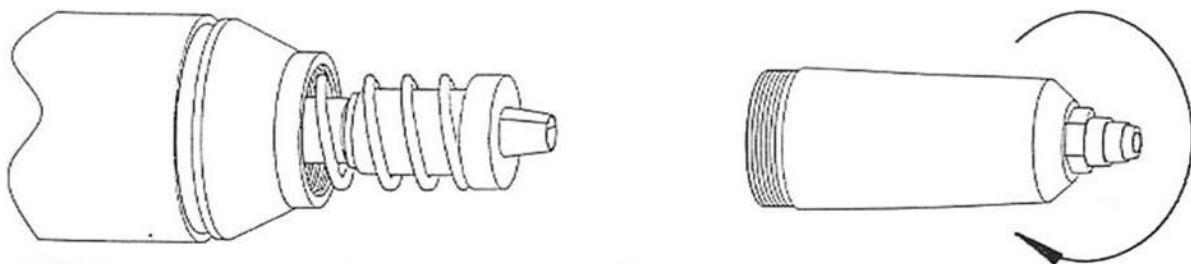

6. Replace the **Nose Tube** and **Nosepiece**, **HAND TIGHTEN ONLY**. The tool is ready for use.



Steps for Proper Tool Maintenance and Operation

1. Disassemble and clean nose components periodically or if the pintails do not drop out freely, use a pick to clean the jaw grooves. Wash components in mineral spirits or isopropyl alcohol. Apply a small amount of light weight oil to the jaws and inside of the jaw holder prior to assembly.
2. To ease nose tube and nose piece installation, extend tool by squeezing the actuating trigger.
3. **DO NOT USE TOOL AS A LEVER.** If the rivet pintail is jammed while re-gripping, instead of releasing trigger depressed, push tool nose against work piece for the jaws to get a deeper grip.
4. If the rivet pintail is stuck in the tool after breaking, lightly tap the nose against a hard surface while squeezing the releasing trigger. The pintail should fall out.
5. Before operating the tool, make sure that all nose parts have been screwed in **HAND TIGHT**.
6. For longer tool life, do not continue to run the tool at the end of travel.
7. The tool should not be used at temperatures below 35°F unless it is first brought to room temperature and cycled several times. Normal use of the tool after warming, reaching room temperature, should keep enough for proper operation.
8. If the tool will not reverse, remove nose tube and inspect for any foreign matter that might have caused jamming between jaw holder and inside of the nose tube.
9. Frequently check that the nose components do not vibrate loose during operation.

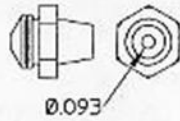
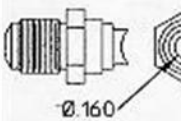
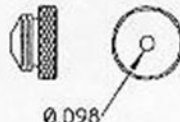
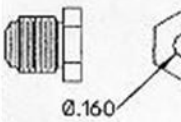
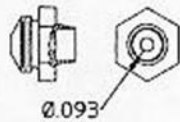
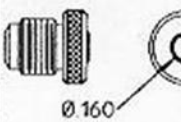
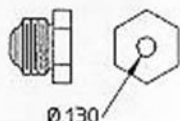
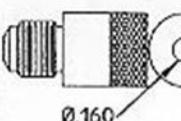
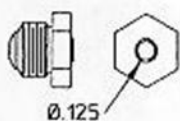
NOSE PIECES

	P/N	Description		P/N	Description
	F156-C	1/8" for Trim Molding Pop Rivets		F155-C	1/4" Auto Split "T" Rivets
0.093			0.160		
	F159-C	3/32" & 1/8" Pop Rivets		F157-C	1/4" Pop & Plastic Rivets
0.098			0.160		
	F190-C	1/8" Stand Off Pop Rivets		F169-C	1/4" Monobolts
0.093			0.160		
	F143-C	5/32" & 3/16" Pop & Plastic Rivets		F193-C	Spec. GM Glass Stop Travel Pop Rivets
0.130			0.160		
	F168-C	3/16" Monobolts		F142-C	1/4" Magna Lok
0.125			0.172		