

## D-100-C Hand Hydraulic Riveter

### Operating Instructions

The D-100-C is a hydraulic tool designed to set from 1/8 inch up to and including 1/4 inch diameter steel, stainless steel, aluminum and plastic rivets by changing only the nosepiece. The has a rated pull pressure of over 3,750 lbs and one handed operation gives access to tight areas.

The Hydraulic system is sealed and oil should not be added. If the D-100-C should be damaged and leaks oil from the tool: **RETURN IT TO AN AUTHORIZED SERVICE CENTER.**



1206 East MacArthur Street • P.O. Box 1372 • Sonoma, California 95476  
Phone: (707) 935-1170 • Toll Free: 800-344-2393 • Fax: (707) 935-1828  
Email: [sales@fsirivet.com](mailto:sales@fsirivet.com) • Website: [www.fsirivet.com](http://www.fsirivet.com)

## General Instructions

The **D-100-C Hydraulic Riveter** uses a pull and release system. Pumping the handles will actuate the tool. The tool must be actuated when installing fasteners or changing nosepieces. After installing the fastener or changing the nosepiece, the tool must be returned to its original position. This releases the pintail if a fastener was installed. To do this, point the tool downward, squeeze **HANDLES** and push in **RELEASING BUTTON**, the pintail should drop out.

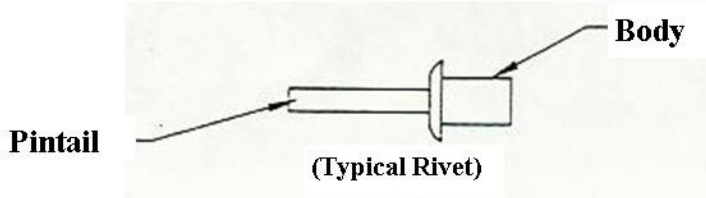

**Nosepiece Installation:** SELECT THE PROPER NOSEPIECE FOR THE CORRECT INSTALLATION OF FASTENER AND FUNCTION OF TOOL. To change the nosepiece, remove the one in the tool by unscrewing it in a counterclockwise direction. Actuate tool until it is fully extended. There should be a gap of approximately  $7/8$ " in between the reservoir shield and the tool body. Hand-tighten the nosepiece into the nose tube and release the tool by squeezing the handles and pressing the releasing button at the same time.

**Fastener Installation:** Install correct nosepiece on tool. Insert pintail of rivet in to the nosepiece. Then position the rivet body in to work piece to be fastened. Hold the tool steady against the work piece and pump handles until rivet is set and pintail is broken. The D-100-C has a  $5/8$  inch work travel and will set most rivets in one cycle (approx. 12 pumps). If the tool reaches the end of its travel before the rivet breaks, **DO NOT** continue pumping the handles on the tool. Release the tool by squeezing the handles and pressing the releasing button, re-grip the rivet, pump the handles and finish the installation.

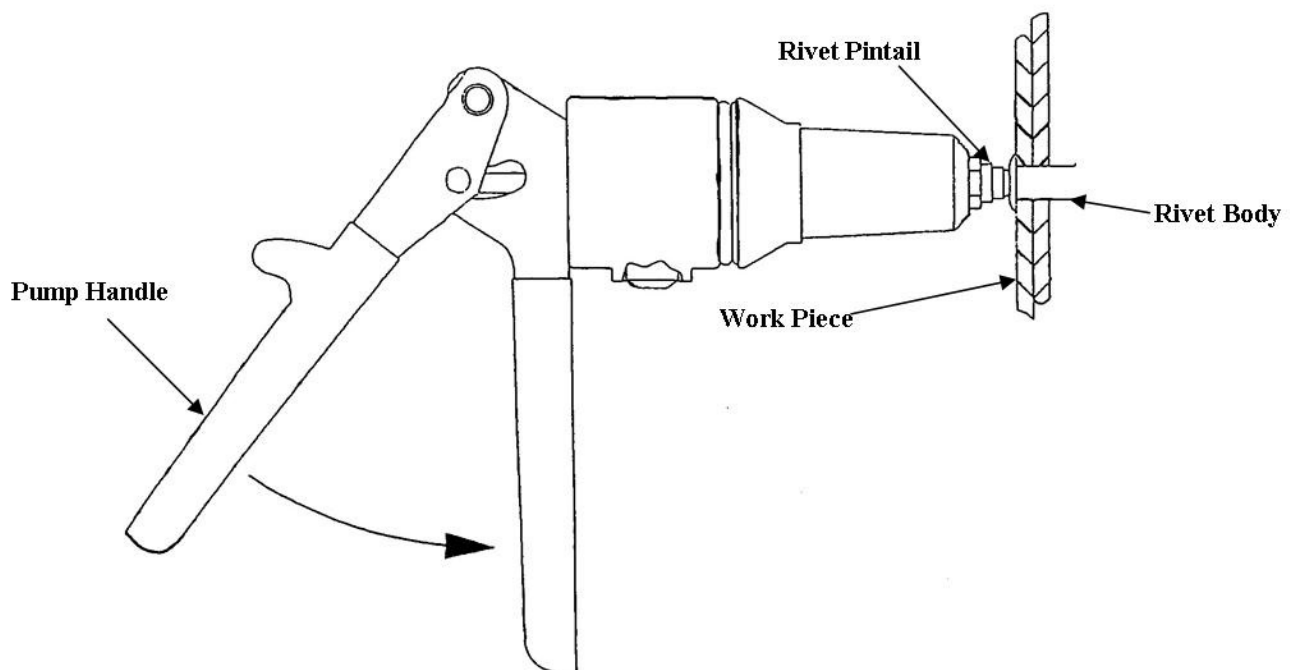

**RIVET PINTAIL REMOVAL:** Once the rivet has been installed, the rivet pintail must be removed. To do this, point the tool downward and squeeze the handles while pressing the releasing button. It is necessary to remove this pintail before attempting to install another rivet.

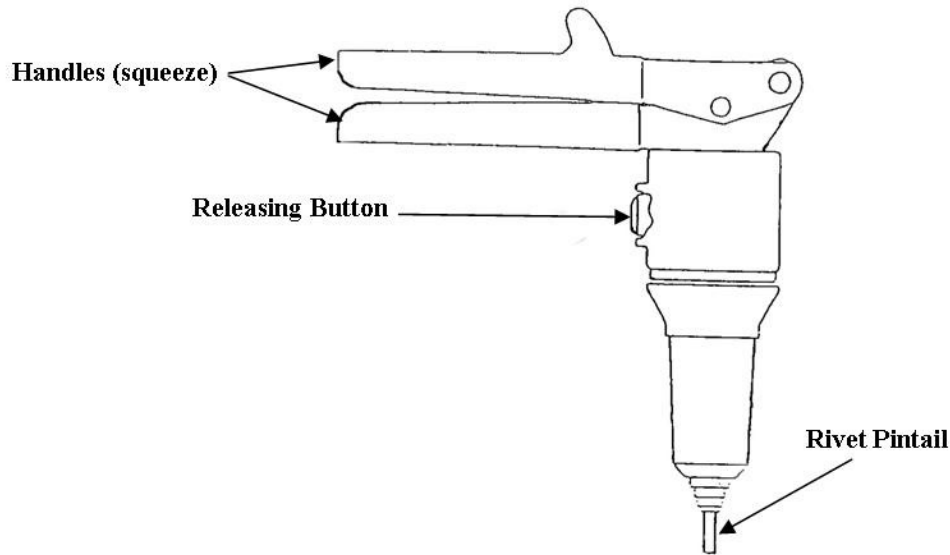

**THREE PIECE JAW INSTALLATION & REMOVAL:** The jaws are installed at the factory and should only need to be removed for periodic inspection and cleaning.

1. To remove the jaws unscrew the nose tube from the tool in a clockwise direction.

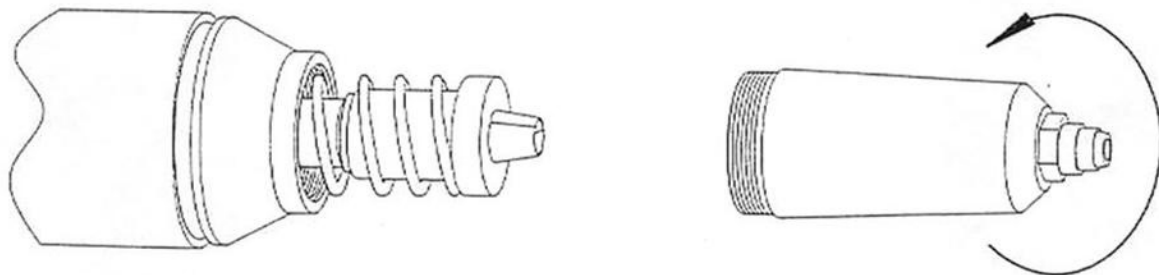

2. Remove the jaw holder by unscrewing it in a counterclockwise direction. Drop jaws out from the spring side. Pump handles (approx. 2-3 times) until jaw pusher is fully extended. Stop pumping handles as soon as the jaw pusher is in extended position.

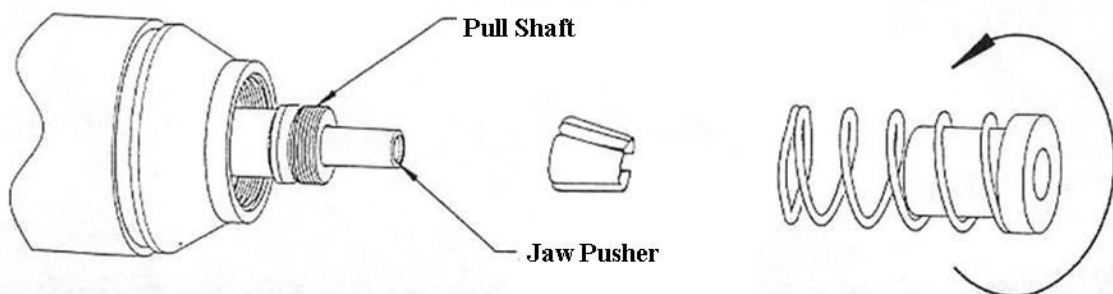

3. To replace **Jaws**, hold **Jaw Holder** large end down and at a slight angle. Place a finger over the small opening and place jaws in one at a time.

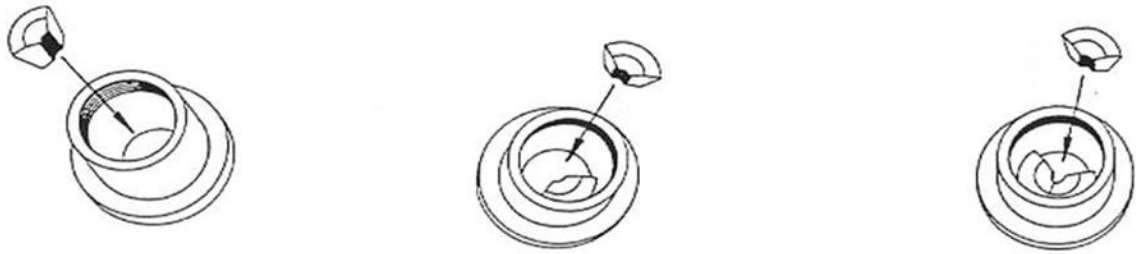

4. When the jaws are in place, insert **Jaw Holder** into **Spring**, being sure to keep large end of **Jaw Holder** pointing downward.

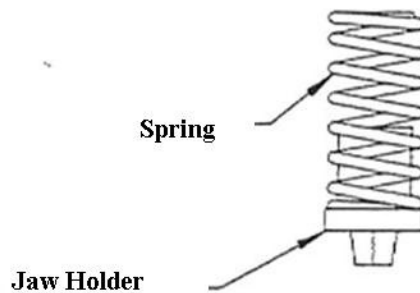

5. Hold tool with the puller shaft pointing down and **Jaw Pusher** fully extended. Screw the **Jaw Holder** on to the **Puller Shaft**. **HAND TIGHTEN ONLY.**

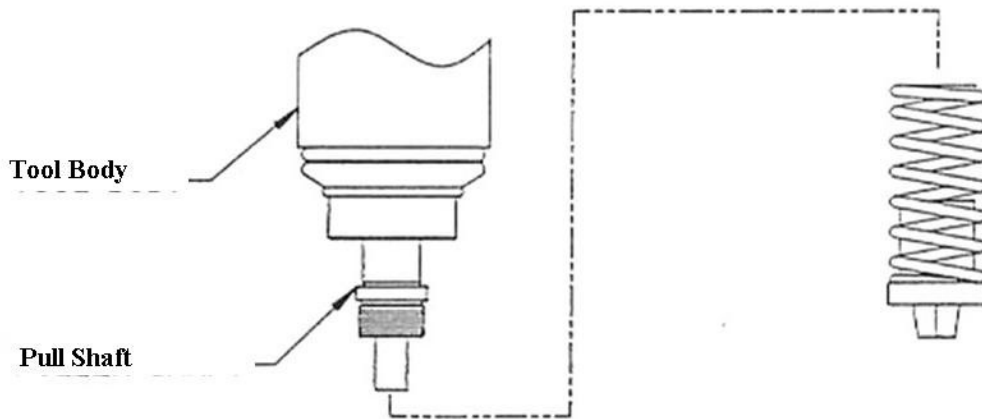

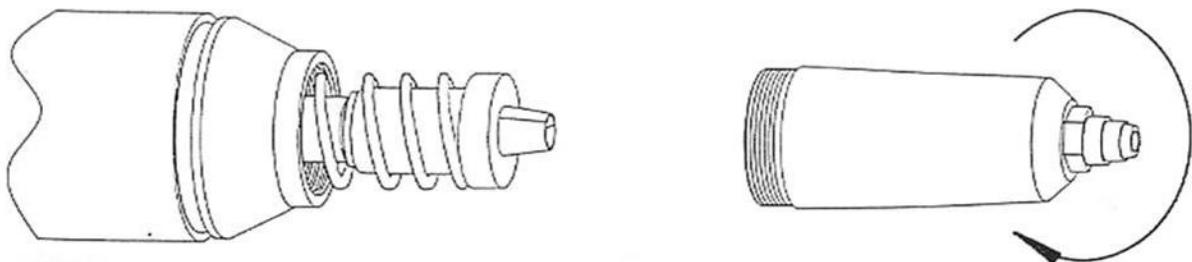

6. Replace the **Nose Tube** and **Nosepiece**, **HAND TIGHTEN ONLY**. The tool is ready for use.



## Steps for Proper Tool Maintenance and Operation

1. Disassemble and clean nose components periodically or if the pintails do not drop out freely, use a pick to clean the jaw grooves. Wash components in mineral spirits or isopropyl alcohol. Apply a small amount of light weight oil to the jaws and inside of the jaw holder prior to assembly.
2. To ease nose tube and nose piece installation, extend tool by pumping handles.
3. **DO NOT USE TOOL AS A LEVER.** If rivet pintail is jammed while re-gripping, instead, squeeze handles and press the releasing button while pushing tool nose against work piece for the jaws to get a deeper grip.
4. If rivet pintail stuck in tool after breaking, lightly tap nose against a hard surface while squeezing handles and pressing the releasing button with tool pointing downward, pintail should then fall out.
5. Before operating the tool, make sure that all nose parts have been screwed in **HAND TIGHT**.
6. The tool has a 5/8" work travel, the completion of which is indicated by a solid stop after approximately 12 pumps (one cycle). **DO NOT FORCE BEYOND THIS POINT** to insure long life of tool.
7. The tool should not be used at temperatures below 35°F unless it is first brought to room temperature and cycled several times. Normal use of the tool after warming, reaching room temperature, should keep enough for proper operation.
8. If the tool will not reverse, remove nose tube and inspect for any foreign matter that might have caused jamming between jaw holder and inside of the nose tube.
9. Frequently check that the nose components do not vibrate loose during operation.
10. **DO NOT ROCK TOOL when pumping it.** This may cause rivets to prematurely break.
11. Large fasteners can be set one handed in tight areas by using short pump strokes.

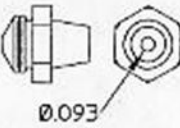
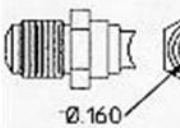
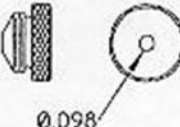
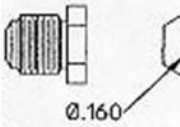
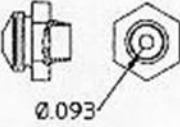
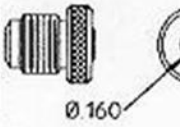
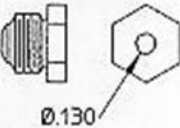
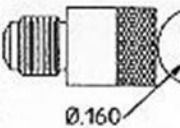
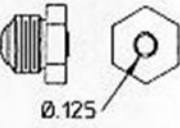
### NOSE PIECES

	P/N	Description		P/N	Description
	F156-C	1/8" for Trim Molding Pop Rivets		F155-C	1/4" Auto Split 'T' Rivets
Ø.093			Ø.160		
	F159-C	3/32" & 1/8" Pop Rivets		F157-C	1/4" Pop & Plastic Rivets
Ø.098			Ø.160		
	F190-C	1/8" Stand Off Pop Rivets		F169-C	1/4" Manobolts
Ø.093			Ø.160		
	F143-C	5/32" & 3/16" Pop & Plastic Rivets		F193-C	Spec. GM Glass Stop Travel. Pop Rivets
Ø.130			Ø.160		
	F168-C	3/16" Manobolts		F142-C	1/4" Magna Lok
Ø.125			Ø.172		

## Conversion Instructions:

1. Completely retract the tool by squeezing handles and pressing the release button.
2. Remove Nosepiece from Nose Tube, Nosepiece, Jaws and Jaw Holder. The tool is ready to start adding Nutsetter accessories. The parts that were removed should be stored for future use as a riveter.
3. Screw Mastershaft assembly on puller shaft and replace Nose Tube.
4. Slide Turn Nut over extended section of the Master Puller Shaft. Screw the appropriate Pull-up Stud into Master Shaft Assembly. (NOTE: this is a left handed thread and must be screwed on counterclockwise.)
5. Push appropriate Anvil over pull-up stud into Turn Nut.

