

D-700C

Hand-Powered Riveter
PATENT PENDING



FSI

**FASTENING SYSTEMS
INTERNATIONAL**

1206 E. MacArthur Street
Sonoma, CA 95476 USA
Tel: 1-707-935-1170
Fax: 1-707-935-1828
www.fsirivet.com

TABLE OF CONTENTS

Description	3
Fluid Used, - type, safety	3
Safety Warnings	4
Ergonomic and Operational Adjustments	4
Lever Span Adjustment	4
Load	4
Tool Operation, Recommended Pulling Heads	4
Troubleshooting Guide	5
Maintenance and Repair	5
Service	5
Hydraulic pump service	6
Pressure relief valve service	6
Piston and adaptor	6
Final assembly	6
Fill and Bleed Instructions	6
Checking fluid level	7
Replenishing fluid	7
Parts List	7
Exploded View	8
Contact / Warranty Information	BACK COVER

DESCRIPTION

D-700C is a lightweight ergonomic hand powered riveter providing means to install a wide variety of blind type fasteners in the absence of other power sources (compressed air or electricity). It combines the safe and smooth operation of well-known pneumatic hydraulic riveters with the latest research in automatic systems.

It features an “intelligent” power optimization system that provides high installation loads at low hand effort. Its durable, all metal design makes this powerful and robust tool ideal for use in rugged repair facilities and field repair.

D-700C features a high strength steel mounting system compatible with the previous D-700A and D-100.

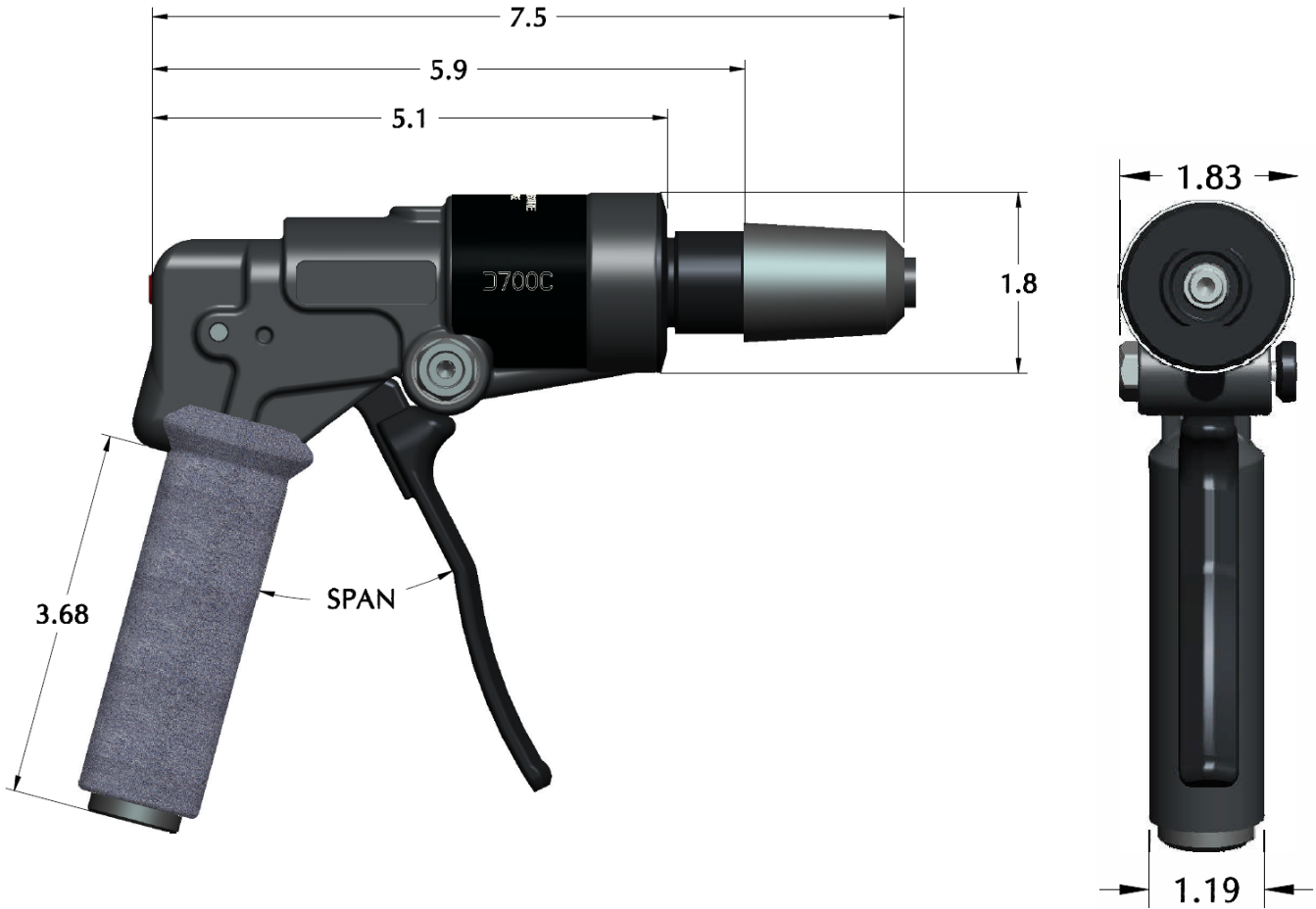

SPECIFICATIONS

Fastening Systems International, Inc policy is one of continuous development. Specifications shown in this document may be subject to change which may be introduced after publication. For the latest information always consult FSI.

STROKE	PULLING CAPABILITY	POWER SOURCE	HAND EFFORT (Lbs)	WEIGHT (INCLUDING PULLING HEAD)
0.750"	Above 5000 Lbs-F	Hand Pump	30 @ 3000 Lbs.	1.96 Lbs.

SAFETY WARNINGS

- Do not operate the tool when it is directed at any person and do not pull rivets in the air.
- Do not pump beyond your hand strength capability; use of two hands to complete an installation is OK
- Do not exceed a maximum output load adjustment of 5500 Lbs;
- Do not throw, drop or use the tool as a hammer.
- Do not use the tool beyond its design intent.
- Consult the tool manual before disassembly, troubleshooting or repair. It is advised that major repairs be undertaken by personnel trained by Fastening Systems Int'l, Inc. (FSI); contact us with your training requirement.
- Wear appropriate personal protection equipment when operating, repairing, or overhauling this tool.
- Never use Loctite® when mounting offset or right angle pulling heads.
- No component substitutions are authorized; any modification to the tool, pulling heads, accessories or FSI supplied components shall be at the customer's entire responsibility. FSI will be pleased to advise on any proposed modification.
- The tool must be maintained in a safe working condition at all times and examined at regular intervals.
- For maintenance, place the tool in an oil pan; dispose of used fluid properly.
- Avoid excessive skin contact with the fluid. Wash thoroughly after handling the fluid.

ERGONOMIC ADJUSTMENTS

For item and part numbers, refer to the component list and exploded views on page 8.

Lever Span

Tools necessary: 5/32" hex wrench

Adjust how far the pump lever extends from the handle for a comfortable operation; thread set screw 42 in to bring the lever closer, thread-out to increase lever distance- see picture below.

Maximum output load

Tools necessary: 5/32" wrench

This is a maximum output load adjustment; if you need a more precise adjustment contact FSI.

- Thread-out the adjustment screw (33) to lower the load, thread-in to increase it;

Cautions: Do not thread out beyond flush with the pressure relief body (36) – see picture below.

- Do not exceed a maximum output load adjustment of 5500 Lbs;

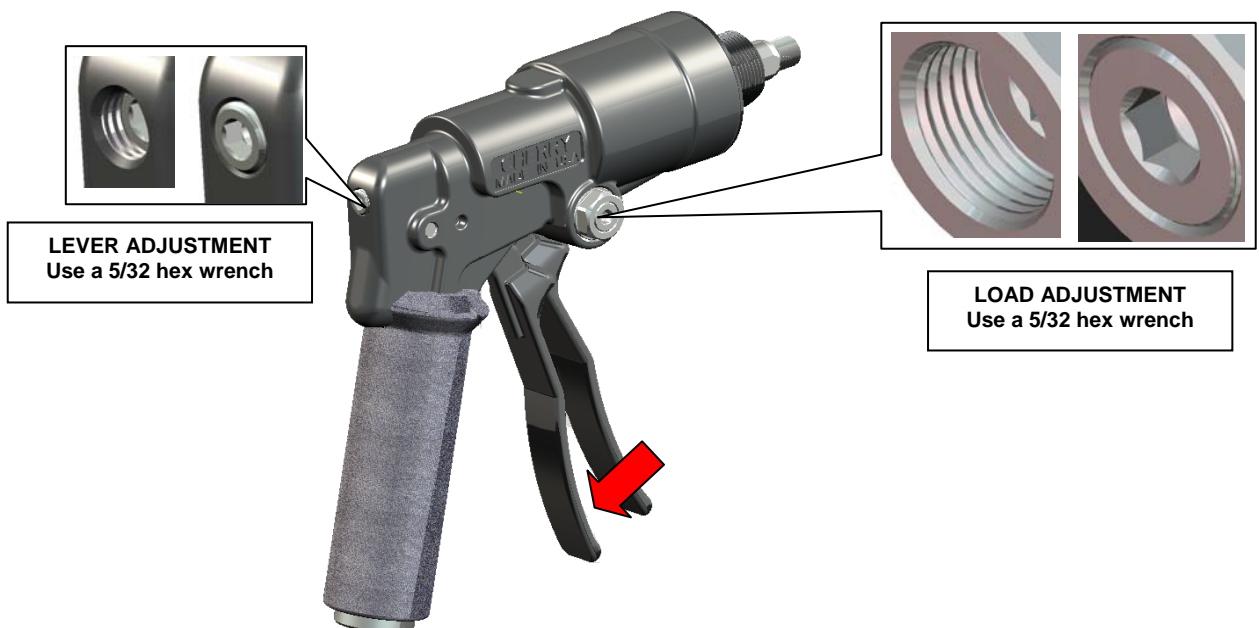

TOOL OPERATION

Prior to using the hand riveter, make sure that:

- The piston is fully returned forward by depressing the side pressure relief button (48)
- The hand lever is properly adjusted for comfortable operation
- The correct pulling head is properly mounted; see pulling head documentation for additional instructions

Fastener Installation

- Insert the blind fastener into the structure and place the riveter onto the rivet stem.
- Hand pump to complete installation; after each pump allow the lever to fully return to its original position. Short stroking is not recommended as it will increase the number of pumps.
- Depress the pressure relief button and allow the broken stem to eject through the front

RECOMMENDED PULLING HEADS

- Contact FSI at 1-800-344-2393 or 707-935-1170 or by e-mail at sales@fsirivet.com for recommendations.

TROUBLESHOOTING GUIDE

For item and part numbers, refer to the component list and exploded view on page 8.

The stem of the fastener to be installed won't fit;

- Make sure the correct pulling head is used, and that it is properly adjusted (the jaws should free the broken stem when the side button is depressed)
- Check for jammed stems inside the jaws; press the side button to properly eject the stem

The stems will not break to complete the installation

- Check the jaws- replace or clean them as necessary.
- Make sure that the proper pulling head and optional components are used
- Check the fluid level; replenish if low.

Nothing happens when I pump

- Check the fluid level –add fluid as needed
- Re-adjust to increase output load
- Service or replace the pressure relief valve
- Disassemble and clean thoroughly the internal components; debris or contamination in the fluid will cause the internal valves to malfunction.

Too easy or too hard to pump (it doesn't seem to shift)

- Replace or service the stage piston (20);

Output piston goes back and forth as I pump

- Make sure that the hollow set screw (14) is threaded in properly and has not backed off.
- Unthread set screw (14), remove and inspect the compression spring (15); replace if damaged. Clean the valve cavity before re-assembling

The lever bounces back forcefully preventing you to pump

 Disassemble and service the reservoir piston (44)

Fluid traces that keep coming back even after wiping off the tool.

- Fluid leaks are caused by worn seals. Disassemble and replace the seals in the area where leaks are noticed.
- To keep the tool in optimum operating condition we recommend inspecting and replacing all the seals as necessary (see tool service, page 6)

MAINTENANCE AND REPAIR

This riveter was designed to be robust and require minimum troubleshooting and maintenance. In order to keep it in optimum operating condition, inspect routinely for leaks and damage and check the fluid level.

TOOL SERVICE

For item and part numbers, refer to the component list and exploded views on page 8.

- Place the riveter over an oil pan to avoid and contain fluid spills; clean up and dispose of used fluid properly.
- Use care handling the internal components and valve cavities; nicks or scratches may make components unusable.
- Make sure that you have all the tools necessary before proceeding to service the tool.
- Apply an O-ring lubricant to all seals and mating surfaces.
- When installing Back-up Rings, make sure the curved surface faces the O-ring.
- Use Loctite® only where indicated; use of Teflon tape is prohibited.
- Handle with care and clean components thoroughly; avoid contamination as it causes internal valve malfunction.

Tools needed:

- F800KS maintenance kit , Loctite® 545 (or comparable)
- 1/16", 1/8" and 5/32" hex wrenches,
- 2" deep socket hex wrench, 9/16" size
- Adjustable wrench, a pair of pliers
- Bent hook for O-ring removal
- Oil Pan large enough to contain fluid spills

BEFORE TAKING THE TOOL APART

Remove the foam handle by twisting and pulling it off; if removal is not possible, it may need to be cut off and replaced. With the 5/32" hex wrench remove the side screw, spring and ball (45, 46, 15 & 16); place them in a clean area.

HYDRAULIC PUMP SERVICE

Unthread and remove the front Adaptor (2). Unthread the hydraulic pump with a 9/16" deep socket wrench and pull it out carefully; you may need to extract it with the help of a pair of pliers (grab on the smaller diameter towards the front). Place pump assembly in a vise and unthread item 16 (use the socket wrench). Push the stage piston (20) out so the O-rings are accessible for replacement. Unthread set-screw 14 with the help [of the 1/8 hex wrench and remove the spring and ball (15 & 16); clean the ball and cavity carefully with a soft, lint free piece of cloth. Replace spring (15), re-assemble with ball (16) and thread-in the set-screw (14) flush with the front surface of item 17. Replace O-ring 18.

Place stage piston (20) in a vise, unthread the cap (21) and clean it. Inspect the edge of the hole facing the ball to make sure it is clean and in good condition, free of nicks and scratches; reassemble the stage piston (20).

Replace the larger O-ring and back-up ring (11 & 12).

Remove O-rings and back-up ring (9, 30, and 31) from the power cylinder (29) and replace them.

Apply O-ring lubricant to all the seal surfaces and push the stage piston (20) back into the power cylinder (29). Re-assemble the rest of the components (17 & 18, 19); use Loctite® on the threads and tighten securely.

The hydraulic pump is now completed.

PRESSURE RELIEF VALVE SERVICE

With the help of the 1/16 hex wrench, unthread the flat head screw (47) while holding the button (48). Pull button (48) out carefully. Unthread the pressure relief valve (32) with a 9/16" deep socket wrench. Unthread the adjustment plug (33) and remove the spring and poppet (25 & 34). Replace the spring with a new one. The seals can now be removed using a bent hook; make sure to remove the seals 38 & 39 from inside the cavity. Clean

and inspect the inside of the valve body and the poppet (34 & 36); replace the seals. Place the poppet and spring (34, 25) back into the body (36) and thread in the adjustment plug (33 - no Loctite® on these threads). Place a new O-ring and back-up ring (38 & 39) onto the poppet stem protruding out of the pressure relief valve.

The valve is now completed.

PISTON AND ADAPTOR

Unthread adaptor (49) and push piston rod (10) out of the adaptor (2). Remove and replace seals (1, 3, 4, 6 & 7). Remove the retaining ring (5) and push piston (8) and rod (10) apart (light tapping with a mallet is OK). Replace O-ring (9) and reassemble piston and rod (8 & 10) by pressing them into each other and secure with the

retaining ring (5). Remove the internal O-ring and back-up ring (11, 12) with a bent hook and replace them. Apply O-ring lubricant to all seal surfaces; push piston rod (10) through the adaptor (2).

Re-assemble and tighten piston rod adaptor (49); use Loctite to secure in place.

FINAL ASSEMBLY

Place the hydraulic pump inside the riveter body and thread it in with the help of the 9/16" deep socket wrench. Make sure it there that the lever is pushed forward and there is no play after fully threading the hydraulic pump in. Place spring (13) inside the riveter body, over the hydraulic pump and thread in the piston and adaptor completed above (use Loctite® on the threads). Tighten the adaptor securely. Prime, fill and bleed the riveter (see next page).

FILL AND BLEED INSTRUCTIONS

To fill and bleed, you will need: a 5/32" hex wrench, a container with the recommended transmission fluid and an oil pan. Make sure to place the tool over an oil pan to avoid and contain fluid spills.

FLUID USED

Use automatic transmission fluid Type "A" (no substitutes). FSI recommends using Dexron® III ATF.

DEXRON III OIL SAFETY DATA

FIRST AID

Skin: Wash thoroughly with soap and water as soon as possible. Casual contact requires no immediate attention. If irritation develops, consult a physician.

Eyes: Flush with copious amounts of water. If irritation develops, consult a physician.

Ingestion: Seek medical attention immediately. DO NOT INDUCE VOMITING.

Inhalation: No significant adverse health effects are expected to occur on short term exposure. Remove from contaminated area. Apply artificial respiration if needed. If unconscious, consult physician.

ENVIRONMENT: Waste Disposal: In accordance with local, state and federal regulations.

Spillage: Prevent entry into drains, sewers and water courses. Soak up with diatomaceous earth or other inert material.

Store the spent fluid in appropriate containers for disposal.

HANDLING: Eye protection required. Protective gloves recommended. Chemically resistant boots and apron recommended. Use in well ventilated area.

COMBUSTIBILITY: It is slightly combustible when heated above flash point. It will release flammable vapors which can burn in open or be explosive in confined spaces if exposed to source of ignition.

FIRE: Suitable extinguishing media: CO₂, dry powder, foam or water fog. DO NOT use water jets.

STORAGE: Avoid storage near open flame or other sources of ignition.

PROPERTIES

Specific gravity	0.863
Weight per gallon	7.18 lbs.
Open flash point	>200°C (392°F)

PRIMING AND FILLING WITH FLUID

- Perform as part of servicing the tool; refer to the Parts List and Exploded Views on page 9.
- Use proper safety equipment per your shop's policy, including rubber or latex gloves.

Step 1. To prepare the tool, remove the handle insulation, side screw, spring and ball (43 & 15, 16, 45 & 46) and place them in a clean, safe place. Unthread and pull the reservoir piston assembly (44) out of the handle and set it aside. Follow the below procedures; select the one that pertains to you situation, depending upon whether you are at a repair facility and a pressurized fluid source is available or not:

A. At repair facility (hydraulic pump or manual oil canister are available): After step one (above) place the spring and ball (15 & 16) back into the side port and thread-in the hydraulic hose from the pressurized fluid source. Turn the riveter up-side so the inside of the handle is visible; depress the pressure relief button and pump fluid through the system using the riveter's lever (in some cases, the fluid pressure may be enough to fill the tool without hand pumping). The fluid level in the handle will increase until it overflows. Watch for air bubbles and keep pumping until no more air bubbles are observed. Remove the hydraulic hose and place thumb over the hole; push the reservoir piston (44) into the handle as far as it goes without threading it in (allow excess fluid to leak out from under your thumb.) Thread in and tighten the side screw and seal (45 & 46). Thread in the reservoir piston (44) and check the fluid level.

B. Field filling (no pressurized fluid supply available): After step 1 (above) thread screw and seal (45 & 46) back in (leave 15 & 16 out). Turn the riveter up-side so the inside of the handle is visible and fill it with fluid. Pump the lever while holding the pressure relief button depressed; the fluid level in the handle will decrease. Re-fill with fluid as needed. Watch for air bubbles resurfacing in the fluid inside the handle while pumping; keep pumping until there are no more air bubbles. Release the pressure relief button and pump until the piston to full stroke. Remove the side screw (46) and place thumb over the hole. Push the reservoir piston (44) into the handle as far as it goes without threading it in (allow excess fluid to leak out from under your thumb.) Re-assemble the ball and spring (15 & 16). Thread in and tighten the side screw and seal (44 & 45). Thread in the reservoir piston (44) and check the fluid level.

CHECKING THE FLUID LEVEL

Turn the riveter upside down and observe the position of the indicator with respect to the silver grooves visible inside the handle.

- **One indicator line is visible:** the tool is full of fluid. The tool was filled and bled properly
- **Two indicator lines are visible:** the fluid level is OK for optimal function
- **Three indicator lines are visible:** the fluid level is dangerously low. Inspect for leaks, service and re-fill as necessary.

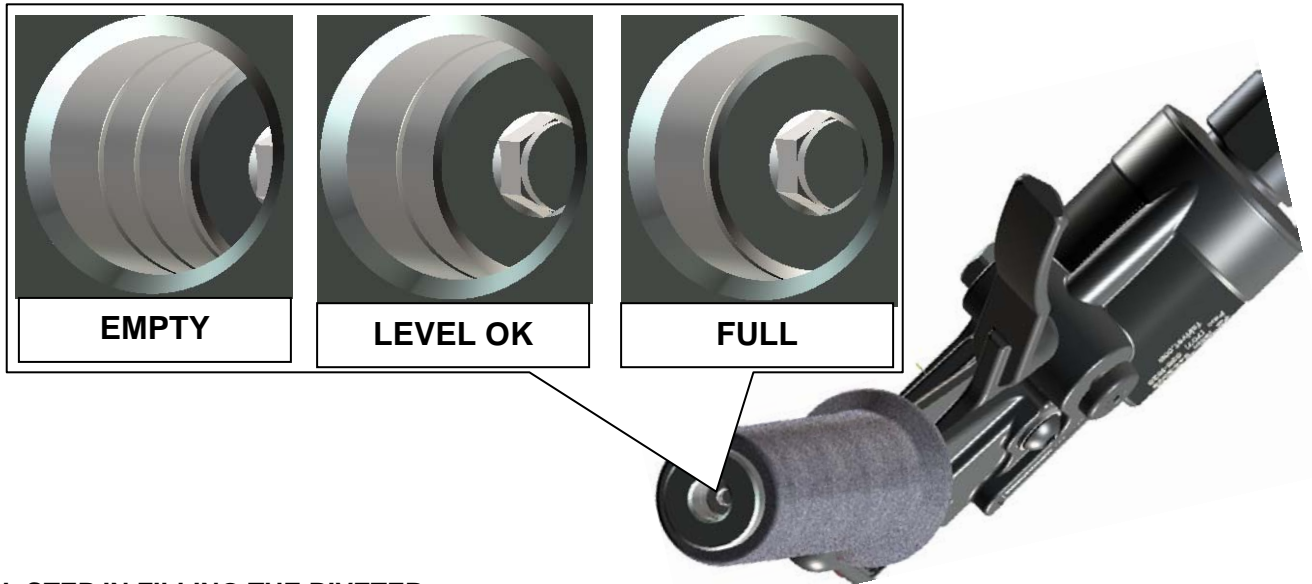

FINAL STEP IN FILLING THE RIVETER

Clean the riveter thoroughly and push the foam insulation (43) all the way over the handle.

This foam insulation is part of the service kit F800KS and we recommend replacing it every time the tool is serviced.

REPLENISHING FLUID

This operation is useful whenever you need to add some fluid in order to restore the fluid level. It cannot be used after completed disassembly; prime and fill with fluid in that case (see previous page).

Tools needed: 5/32" hex wrench and the 700A77 Bleeder Bottle with F1484 adaptor. The Bleed Bottle should have at least 2 fl oz. (about 5 mL) of fluid (recommended fluid on page 7)

- Remove the side screw, spring and ball (15, 16, 45 & 46) and place them in a clean place.
- Attach the bleed bottle to the side hole;
- With the bottle up-side down (see picture) unthread the reservoir piston (44) until fully disengaged; do not pull the piston assembly out of the reservoir. During this process, fluid will be drawn into the reservoir.
- Remove the bleed bottle and place the ball and spring (15 & 16) back into the side port, then tighten the screw and seal (45 & 46).
- Thread-in and tighten the reservoir piston (44); check the fluid level
- If the fluid level is still low, then tool needs to be primed and filled (see page 6).



D-700C PARTS LIST

ITEM	PART NO.	DESCRIPTION	QTY
F800-000 (TOP ASSEMBLY)			
1	F701	O-RING (BLACK, OD 5/8", W .07")	1
2	F800-027	CHERRY HOUSING ADAPTOR	1
3	F1467	O-RING (WHITE, OD 1.5", W .07")	1
4	F1479	SEAL (BLACK, OD 3/4", W 1/8")	1
5	F165	EXTERNAL RETAINING RING (5/8")	1
6	F299	O-RING (OD 1.39" W.14")	1
7	F869	BACK-UP RING (OD 1.39" W.14")	1
8	F800-013	WORK PISTON	1
9	F721	O-RING (WHITE, OD 3/4", W.07")	1
10	F800-026	PISTON ROD (7/16-20UNF)	1
11	F891	O-RING (OD 9/16" W.07")	2
12	F1061	BACK-UP RING (OD 9/16", W.05")	2
13	F1315	COMPRESSION SPRING	1
14	F1476	HOLLOW SET-SCREW	1
15	F1473	COMPRESSION SPRING	1
16	F117	STEEL BALL (3/16")	2
17	F800-011	POWER CYLINDER EXTENSION	1
18	F269	O-RING (OD 15/16" W.07")	1
19	F1463	COMPRESSION SPRING	1
20	F800-006*	STAGE PISTON	1
21	F800-010	PISTON CAP	1
22	F1294	O-RING	1
23	F800-009	POWER PISTON	1
11	F891	O-RING (OD 9/16" W.07")	(1)
12	F1061	BACK-UP RING (OD 9/16", W.05")	(1)
15	F117	STEEL BALL	(1)
24	F800-008	SHIFT PISTON	1
25	F1383	COMPRESSION SPRING	1
26	F1475	O-RING	1
27	F1471	BACK-UP RING	2
28	F800-007	POWER PISTON ROD	1

ITEM	PART NO.	DESCRIPTION	QTY
29	F800-005	POWER CYLINDER	1
30	F383	O-RING (OD 7/16", W.07")	2
31	F732	BACK-UP RING (OD 7/16, W .05")	1
32	F800-018*	PRESSURE RELIEF VALVE	1
33	F800-021	ADJUSTMENT PLUG	1
25	F1383	COMPRESSION SPRING	1
33	F800-020	VALVE POPPET	1
1	F701	O-RING (OD 5/8", W .07")	
35	F194	O-RING	
36	F800-019	BODY, PRESSURE RELIEF	
37	F1474	O-RING (WHITE, OD 9/16" W.07")	1
38	F293	O-RING (OD 5/16", W.07")	1
39	F1472	BACK-UP RING (OD 5/16, W .05")	1
40	F800-028	CHERRY AEROSPACE LABEL	1
41	F800-002*	RIVETER BODY	1
42	F1465	SET-SCREW	1
43	F1469	FOAM HANDLE	1
44	F800-023*	REZERVOIR PISTON ASSEMBLY	1
1	F701	O-RING (OD 5/8", W .07")	1
45	F670	STAT-O-SEAL	1
46	F1464	BUTTON HEAD SCREW	(1)
47	F1470	FLAT HEAD SCREW	1
48	F800-022	PLASTIC BUTTON	1
49	F800-041	PISTON ROD ADAPTOR BUSHING	1

* Must be ordered as a sub-assembly.

No substitutions

SUBASSEMBLY EXPLODED VIEWS

STAGE PISTON (item 20)
EXPLODED VIEW

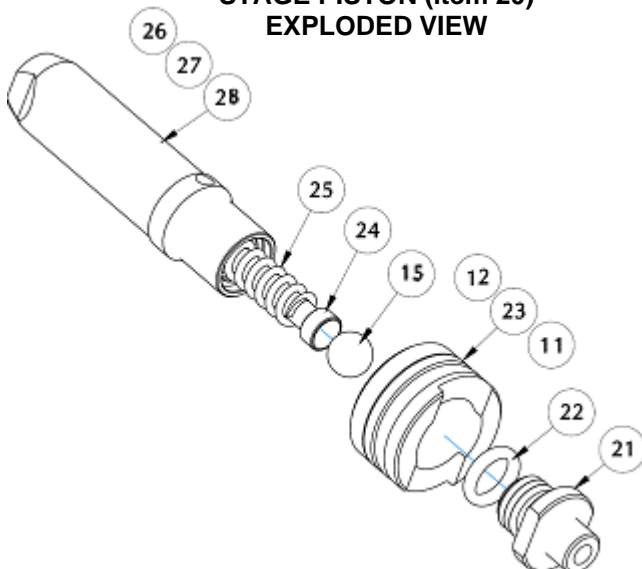

PRESSURE RELIEF VALVE (item 32)
EXPLODED VIEW

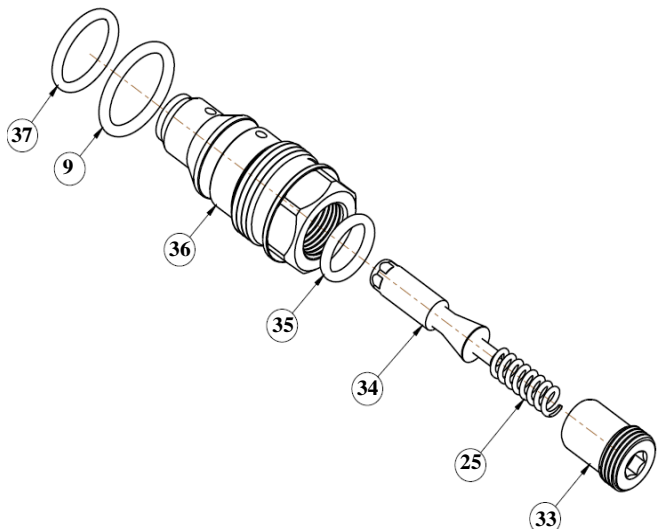

D-700C
TOP ASSEMBLY
EXPLODED VIEW

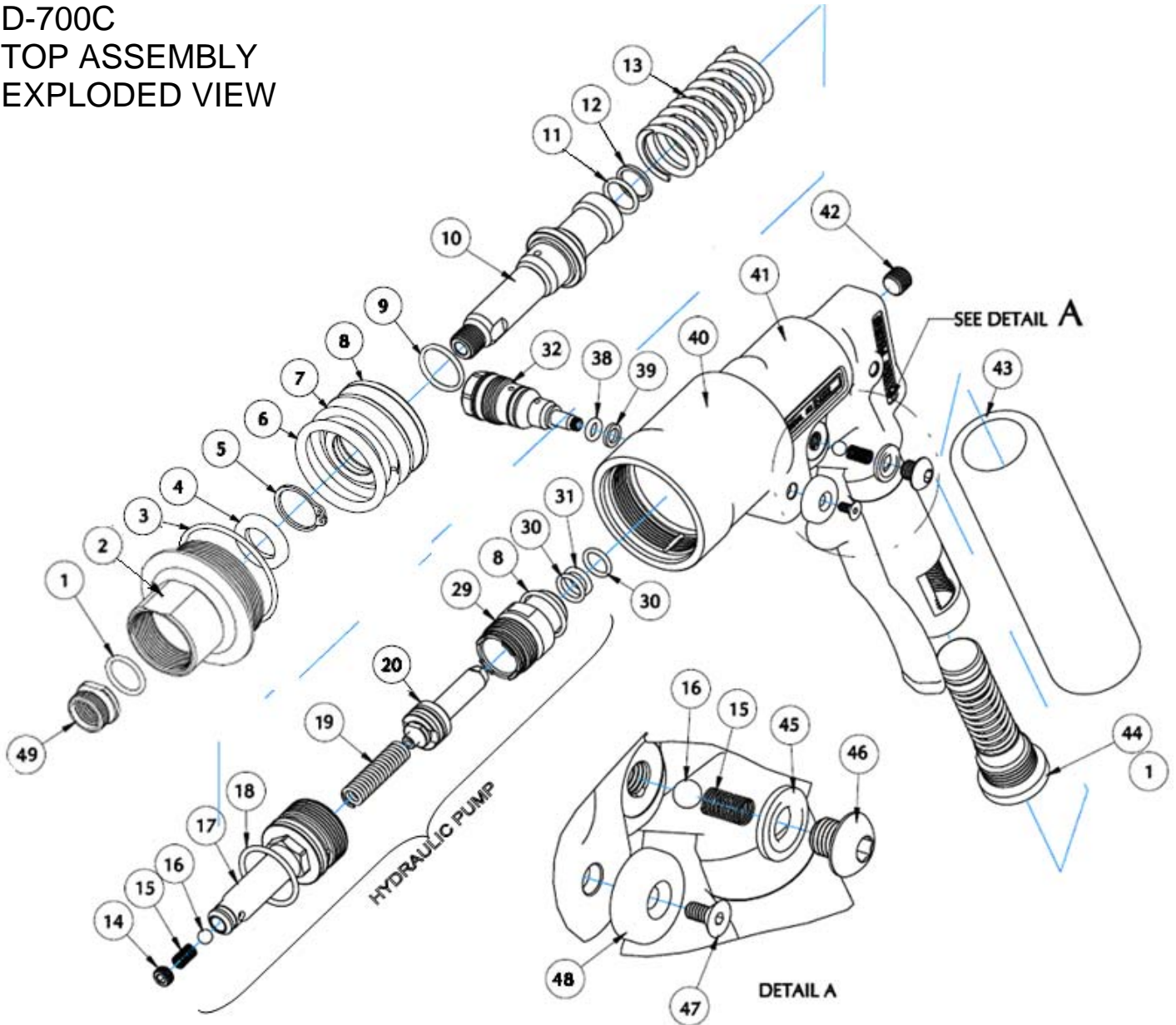

WARRANTY

Seller warrants the goods conform to applicable specifications and drawings and will be manufactured and inspected according to generally accepted practices of companies manufacturing industrial or aerospace fasteners. In the event of any breach of the foregoing warranty, Buyer's sole remedy shall be to return defective goods (after receiving authorization from Seller) for replacement or refund of the purchase price, at the Seller's option. Seller agrees to any freight costs in connection with the return of any defective goods, but any costs relating to removal of the defective or nonconforming goods or installation of replacement goods shall be Buyer's responsibility. SELLER'S WARRANTY DOES NOT APPLY WHEN ANY PHYSICAL OR CHEMICAL CHANGE IN THE FORM OF THE PRODUCT IS MADE BY BUYER.

THE FOREGOING EXPRESS WARRANTY AND REMEDY ARE EXCLUSIVE AND ARE IN LIEU OF ALL OTHER WARRANTIES AND REMEDIES; ANY IMPLIED WARRANTY AS TO QUALITY, FITNESS FOR PURPOSE, OR MERCHANTABILITY IS HEREBY SPECIFICALLY DISCLAIMED AND EXCLUDED BY SELLER. THIS WARRANTY IS VOID IF SELLER IS NOT NOTIFIED IN WRITING OF ANY REJECTION OF THE GOODS WITHIN ONE (1) YEAR AFTER INITIAL USE BY BUYER OF ANY POWER RIVETER OR NINETY (90) DAYS AFTER INITIAL USE OF ANY OTHER PRODUCT.

Seller shall not be liable under any circumstances for incidental, special or consequential damages arising in whole or in part from any breach by Seller, AND SUCH INCIDENTAL, SPECIAL, OR CONSEQUENTIAL DAMAGES ARE HEREBY EXPRESSLY EXCLUDED.

For more information please contact FSI Technical Services Department at Tel. 707-935-1170