



PT-3000

Operating Instructions



1206 East MacArthur Street • P.O. Box 1372 • Sonoma, California 95476
Phone: (707) 935-1170 • Toll Free: 800-344-2393 • Fax: (707) 935-1828
Email: sales@fsirivet.com • Website: www.fsirivet.com

PT-3000 Rivet Capacity

The PT-3000 pulls most all pull style blind rivets including CherryMax and Cherry "A" Max thru 3/16" diameter in all materials and Blind Bolts and Maxibolts thru 1/4" diameter.

Equipment/Accessories

Nosepieces:	3/32 thru 1/4
Wrench:	SW 12 (covers nosepiece compartment)
Suspension Loop:	Flips open from housing
Battery:	Quick Charge/ 12 Volt DC

Technical Data

Weight:	4.85 lbs (with battery)
Stroke:	787"
Drive Unit:	12 V direct current motor
Traction Power:	1,900 lbs.

Nosepiece Rivets Per Battery Table: Charge

Rivet Dia.	Rivet Body Material	*Rivets Per Charge	Nosepiece Part No.
3/32"	Aluminum	1,900	F140
1/8"	Aluminum	1,300	F159
1/8"	Steel	1,100	F159
1/8"	Stainless Steel	1,000	F159
5/32"	Aluminum	1,000	F143
5/32"	Steel	900	F143
5/32"	Stainless Steel	800	F143
3/16"	Aluminum	700	F143
3/16"	Steel	500	F143
3/16"	Stainless Steel	400	F143

* Rivets per battery charge based on Mil-R-24243 style blind rivets in maximum grip condition

Starting Procedure

Install fully charged battery into housing. Select proper nosepiece (see page 2) and screw into head.

Attention: Do not cover or stick anything into the vent holes.

Operating Procedure

Pushing the trigger starts the operation. When releasing the trigger, the jaw mechanism returns to the start position automatically.

Eject the spent mandrel into the mandrel container by tilting the tool backward, or through the nosepiece by tilting tool forward.

The riveting tool is equipped with overload protection. In case if an overload, the operation will be stopped and the red light goes on. If that happens, release the trigger and the mechanism will return to the start position.

The battery will deliver uniform power for tool operation until depleted to the last 2-3 rivets of charge capacity. It is designed to have the jaw mechanism return to the starting position when the trigger has been released.

Maintenance

The maintenance of the riveting tool is limited to the complete jaw mechanism and the included wearing parts.

Remove the battery (#40) from the tool housing. Unscrew the head (#13) from the tool and clean it. Unscrew the jaw housing (#12) from the coupler. Take out the jaws (#11), clean and lubricate or replace if worn. Reassemble in reverse order and make sure that all parts are tightened!

Warranty

There is a 6 month warranty from the day of delivery on the PT-3000. Damages caused by common wearing, overloading or improper usage or handling are excluded from the warranty. Damages caused by material or manufacturing faults will be covered by this warranty and will be repaired or replaced at no cost. Claims can only be accepted if the complete riveting tool, fully assembled, is returned to the distributor or FSI.

Trouble Shooting

Blind Rivet Cannot be Set

Causes

Depleted battery charge
Jaws dirty or worn
Jaw pusher spring weak
When trigger is pressed, no function
(red indicator light shows)

Remedy

Recharge, if necessary replace
Clean and lubricate or replace
Tighten
Replace

No Spent Mandrel Discharge

Causes

Wrong nosepiece
Nosepiece worn
Mandrel jammed in jaws

Head Dirty inside
Spent mandrel container filled
Passage clogged

Remedy

Exchange according to page 2
Replace
Loosen the mandrel, clean and lubricate the
jaws or replace
Clean
Remove and empty
Remove clogged mandrels and check for free
ejection

Red Light Indicated Faults

A) When trigger is pressed

Causes

Overheating of electronic control
B) While pulling the rivet

Causes

Overloading
Overheating of electronic control
Depleted battery charge
C) After releasing the trigger

Causes

Jaw mechanism is not reaching the front
position

Remedy

Allow too to cool to ambient temperature

Remedy

Check working capacity
Allow tool to cool to ambient temperature
Recharge or replace

Remedy

Tighten jaw mechanism

Maintenance Instructions

General Notes

Warranty repairs are carried out by the manufacturer only. Repairs outside the warranty period should only be carried out by trained personnel. The following instructions must be strictly adhered to, as assembly or adjustment errors may cause major damage to the PT-3000.

Repair Tools & Lubricant

For repair of the PT-3000, the following should be available:

Screw Driver Torx T 20
Hexagonal Wrench SW 2.5 mm
Open End Wrench 27 mm
Open End Wrench 17 mm
Open End Wrench 14 mm
Lubricating Grease (#46)

Dismantling the PT-3000

Remove battery (#40) from the tool. Unscrew spent mandrel container (#39). Remove housing screw (3 pcs. #32 & 5 pcs. of #33) with screw driver Torx T 20.

Take off hand guard (#31). Take off top of tool housing (#1) and pull off the red and blue connecting wires from the electronic control (#26). Unscrew electronic control (#26) using screw driver Torx T 20.

Unscrew magnet holder (#27) using the hexagonal wrench SW 2.5mm. Take out electronic control (#26) and magnet holder (#27). Take out motor (#25).

ATTENTION: Reassembly Tip: Note how connecting wires to the motor are laid out in the tool housing!

Take out drive system (#42). Unscrew head (#13) using open end wrench SW 27mm. Unscrew jaw housing (#12) using open end wrench SW 17mm and take out jaws (#11), jaw pusher (#10) and jaw pusher spring (#9).

Unscrew jaw housing coupler (#7) with scraper ring (#8) using open end wrench SW 14mm.

Remove screws (4 of #6) using hexagonal wrench SW 2.5mm. Pull off drive bearing (#3) and pinion shaft (#4) with snap ring (#6) and bushing (#20).

Assembly & Stroke Adjustment

Assembly of Drive System (#42) Slip drive bearing (#3) over ball screw drive (#2) and put pinion shaft (#4) together with snap ring (#5) in bearing place.

Attention: Before screwing ball screw drive (#2) and drive bearing (#3) together, make sure the locating marking “B” of the bearing disk inside the ball screw drive (#2) is placed opposite the pinion shaft (#4). See Parts Drawing.

Assemble this entire unit together with the 4 screws (#6) using hexagonal wrench SW 2.5mm. Screw jaw housing coupler (#7) with scraper ring (#8) onto ball screw using open end wrench SW 14mm.

Put jaw pusher spring (#9) and jaw pusher (#10) onto jaw housing coupler (#7). Place the jaws (#11) in jaw housing (#12) and screw this onto jaw housing coupler (#7) using open end wrench SW 17mm.

Screw head (#13) on using open end wrench SW 27mm.

Assembly of the PT-3000

The sub-assemblies and other parts should be put into tool housing half (#1) containing the nosepiece bracket as follows:

To install drive system (#42), slip the bushing (#20) onto the shorter end of the pinion shaft (#4) while ensuring that the snap ring (#5) is pressed to the gear.

To insert the tube (#22), the longer end of the tube must be inserted into the ball screw, while the collar of the tube must be inserted into the provided recess of the tool housing.

To place the motor connecting wire, the red wire should be bent downwards at the soldering tag towards the blue wire, then bent again to be parallel with the blue wire.

To install motor (#25), the two connecting wires are to be placed side by side around the first guiding stud of the tool housing and behind the middle guiding studs. The wires should then be brought up in front of the third guiding stud.

The electronic control unit (#26) should be installed by putting it on the stud inside the tool housing and then fastened with the housing screw (#32). Click magnet holder (#27) in the guiding slot of the electronic control (#26).

Fasten other end of magnet holder (#27) to ball screw drive (#2) with magnet holder screws (#28) together with two spring lock washers (#29) using the hexagonal screw driver SW 2.5. For later stroke adjustment, do not tighten the screws. Plug the two blue connecting wires of motor (#25) and electronic control unit (#26) together.

DO NOT CONNECT RED WIRE YET!!

Stroke Adjustment

Turn gear of pinion shaft until distance “A” measures 0.118” -See Parts Drawing. Then insert battery (#40) correctly in tool housing.

Attention: Positive pole of battery (#40) must be at top to avoid damage of electronic control unit (#26).

While trigger is pressed, magnet holder (#27) must be adjusted in slot of electronic control until red indicator light goes on. After releasing trigger, the two magnet holder screws (#28) must be tightened. NOW connect red wire to electronic control (#26).

Attention: Both connecting wires must be placed around guiding stud on electronic control (#26) in such a way to keep slot free for movement of magnet holder (#27).

Preliminary Motor Test: Motor (#25) is be carefully held down at both ends. Make sure to allow room for magnet holder to move back and forth. Pull trigger to move jaw mechanism about .200 to .400 inches, and release trigger.

Check distance “A” (See Parts Drawing). It must be 0.039” - 0.051”

If distance “A” gap is below 0.039”, magnet holder (#27) should be moved carefully to the right after loosening the two screws (#28) in order to obtain .039 to .051 gap.

If distance “A” gap is larger than 0.051”, magnet holder must be moved to the left accordingly. After tightening the screws (#28), repeat test and recheck distance “A”. Take battery (#40) out of tool housing.

Finishing

Lubricate gear teeth with lubricating grease (#46). Insert suspension loop (#30). Insert hand guard (#31). Replace second half of tool housing.

Tighten both halves of tool housing (#1) together with the five housing screws (#33) and the three housing screws (#32) using screw driver Torx T 20.

Safety Notes

The PT-3000 has been designed and manufactured in accordance with the applicable safety regulations. If the PT-3000 is being used for the intended purpose in accordance with instructions and normal safety measures, there is no danger involved during operation.

WARNING! Never operate the PT-3000 without placing the blind rivet in proper hole of the work piece or material. The rivet could be propelled from the tool. Avoid pointing the tool at anyone during operation.

Safety Notes: Con't

The sent mandrel container (#39) must always be firmly screwed into place on the tool during operation. Do not plug or cover vent holes in tool housing an any time.

Repairs should be carried out by trained personnel only. Otherwise, return PT-3000 to supplier or to FSI.

Do not operate the PT-3000 and the Battery Charger in an environment allowing exposure to moisture, combustibile fluids or gases.

Avoid damage to cord and plug of charger. Inspect regularly for any damage. Ensure that the battery is properly secured in the tool housing.

Take the charger out of steel case when recharging the battery. Place the battery in the correct position (+pole to +pole) and do not force it into the charger.

Always remove the battery before servicing / repairing the PT-3000.

Do not discard batteries into water or fire as danger of explosion exists. Any used battery be disposed of in accordance with environmental regulations.

Do not use the PT-3000 for any function other than riveting, especially not as a hammer.

Safety Notes: Con't

The sent mandrel container (#39) must always be firmly screwed into place on the tool during operation. Do not plug or cover vent holes in tool housing an any time.

Repairs should be carried out by trained personnel only. Otherwise, return PT-3000 to supplier or to FSI.

Do not operate the PT-3000 and the Battery Charger in an environment allowing exposure to moisture, combustibile fluids or gases.

Avoid damage to cord and plug of charger. Inspect regularly for any damage. Ensure that the battery is properly secured in the tool housing.

Take the charger out of steel case when recharging the battery. Place the battery in the correct position (+pole to +pole) and do not force it into the charger.

Always remove the battery before servicing / repairing the PT-3000.

Do not discard batteries into water or fire as danger of explosion exists. Any used battery be disposed of in accordance with environmental regulations.

Do not use the PT-3000 for any function other than riveting, especially not as a hammer.

Safety Precautions

PT-3000 CORDLESS BLIND RIVETER

The PT-3000 Blind Riveter has been designed with safety in mind and it conforms to all applicable regulations governing cordless battery operated tooling. If utilized in accordance with operating instructions, danger free application of the tool is assured.

CAUTION: Do not rivet without the rivet being installed into material. The rivet body and a portion of the mandrel can shoot away from the tool which could cause injury.

Stem canister (Item #39) should always be mounted on the tool to catch spent stems.

The ventilation holes to the electric motor must not be obstructed. Do not cover or place anything over them.

Repairs should only be undertaken by skilled and trained repair technicians. If unsure, send the tool back to your dealer or the factory.

The PT-3000 and the battery charger unit must be kept away from moist / wet surroundings and away from flammable liquids and gases. Do not use in temperatures above 120 degrees F.

Socket, Plug and Charger unit should be routinely inspected, and if damaged, replaced or repaired.

To charge batteries, remove charger from steel case. The battery pack will only fit into charger socket in proper orientation and is installable with a minimum amount of insertion pressure.

When working on the PT-3000 (i.e., replacing jaws, jaw follower or spring) be sure the battery pack is removed from the riveter.

Do not throw battery pack into water or fire as they can explode. The battery pack should be recycled according to instruction manual.

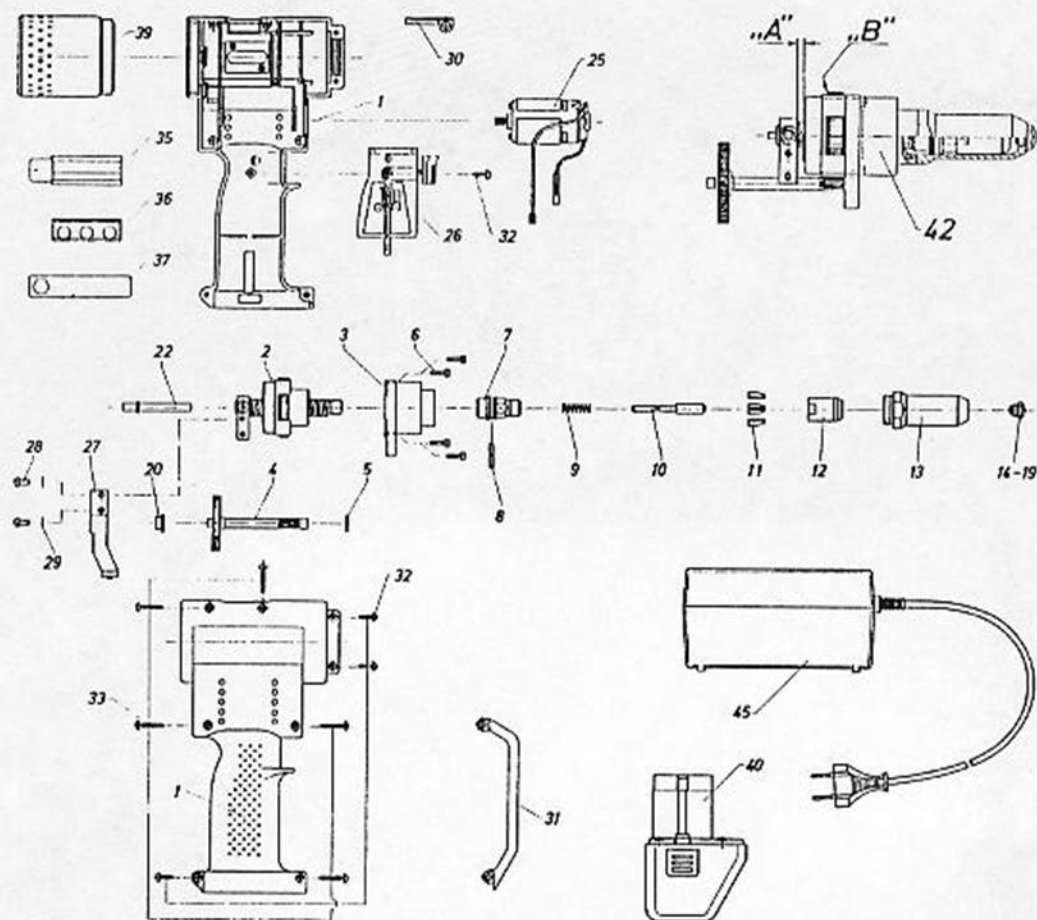

Item	Part-No.	Description	Item	Part-No.	Description
1	F3274	Tool housing, complete	22	F3761	Spent mandrel tube
2	F3142	Ball screw drive, assembled	25	F3223	Motor, complete
3	F3185	Drive bearing, complete	26	F3850	Electronic control
4	F3193	Power transfer gear	27	F3266	Magnet holder, complete
5	F3753	Snap ring	28	F3990	Magnet holder screw
6	F3982	Screw	29	F3008	Spring lock washer
7	F3605	Jaw housing coupler	30	F3559	Suspension loop
8	F3745	Scraper ring	31	F3540	Hand guard
9 *	F3093	Jaw pusher spring	32	F3032	Housing screw, short
10 *	F3621	Jaw pusher	33	F3024	Housing screw, long
11 *	F3123	Jaws (3 parts)	35	F3567	Nosepiece bracket
12	F3126	Jaw housing	36	F3091	Nosepiece holder
13	F3130	Nose tube	37	F3834	Nosepiece wrench
14	F140	Nosepiece, 3/32 Pop	39	F3282	Spent mandrel container
15	F156	Nosepiece, 1/8 Pop	40	F-3001	Battery
16	F159	Nosepiece, 1/8 Pop	41	F3622	1/4 Jaw follower
17	F143	Nosepiece, 3/16 CM	42	F3134	Drive system (Pos. 2-13,15)
18	F168	Nosepiece, 3/16 Monobolt**	43	F142	1/4" Nosepiece**
19	F580	Nosepiece 3/16 MS**	45	F-3000	Battery charger
20	F3893	Bushing	46	F3555	Lubricating grease

*** Wearing Parts**

****Note:** To install 3/16" MS20600 rivets or 1/4" diameter all aluminum pop rivets, or any other 1/4" diameter all aluminum rivet the PT-3000 is capable of installing, you must replace Item 10 (F3621) with Item 41 (F3622).

PT-3000-MIL-1 CORDLESS BLIND RIVETER

ATTACHMENT OF SPECIAL RIGHT ANGLE, EXTENDED STRAIGHT, & OFFSET PULLING HEADS FOR CHERRYMAX

Instructions:

1. Be sure the riveter is in its full forward position.
2. Remove 12 V Battery Pack (Item #1) from handle.
3. Unscrew nosetube (Item #2), jaw holder (Item #3), and remove three (3) piece jaws (Item #4) and place them in spare parts canister provided in steel case.
4. Remove jaw follower / ejector tube (Item #5) and spring (Item #6). Place spring in spare parts canister. The jaw follower / ejector tube may be reinserted into the drawbolt assembly or stored in a safe place until needed. (Note: Do not leave spring on jaw follower if follower is stored in tool.)
5. Next, thread adapter puller shaft (Item #7) onto drawbolt assembly. Tighten. Thread adapter sleeve (Item #8) into housing and tighten using flats provided. (See Diagram, Next Page)
6. Select desired pulling head for use.

NOTE: The PT-3000 Riveter has .79" stroke. The standard Cherry Max rivet requires less than .5" stroke to install. Therefore, the pulling heads, in the case of the offset and right angle, do not allow for much more than .5" stroke. If this stroke is exceeded, the tool will go into overload, and the red indicator light built into the handle will come on to indicate an overload. The indicator light will also turn to red if the tool's internal temperature exceeds 185 degrees F.

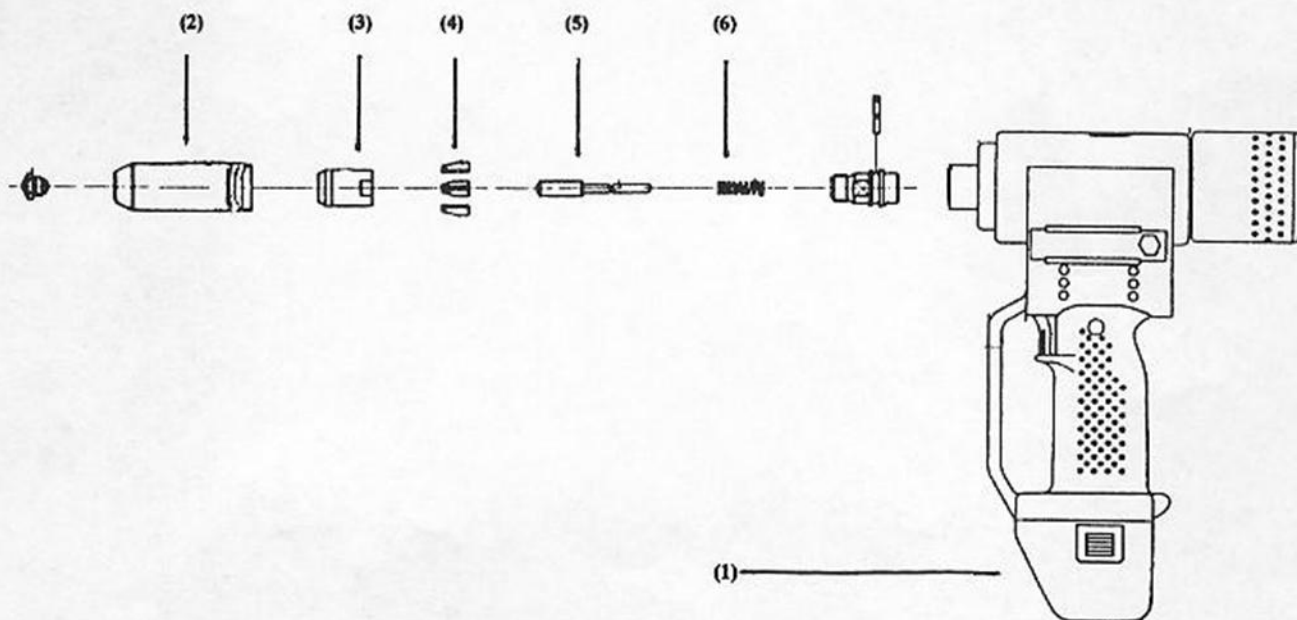

Pulling Head Assembly

Right Angle Pulling Head (F-1075): After steps 1 thru 6, thread the internal threads of the pulling head's draw bolt two or three turns onto the adapter puller shaft. Next, engage the threads of the pulling head housing and continue threading into place. To minimize stroke requirement and to set a particular rivet size, simply adjust the nose tube of the right angle head by loosening the jam nut at its base.

Extended Straight (F-1074): Thread the extended straight pulling head's jaw holder assembly (Item #9) onto the adapter puller shaft assembly (Item #7). (Tighten by putting rivet stem into adapter puller shaft hole to keep it from rotating.) Next, take the straight pulling head's jam nut (Item #10) and back it off at least ten full turns from the end. Now thread the adapter sleeve (Item #8) into place, approximately six full turns. Use the red marker on the jam nut to aid in counting. Next, engage battery pack into tool and fully retract the draw bolt / jaw holder assembly. While keeping the jaw holder fully retracted, insert desired rivet stem into nosepiece (to set up for use with all sizes 3/16 oversize). Now allow the jaw holder assembly to come forward. If it easily accommodates the stem (ie, you can move it in and out freely), you can now tighten the jam nut into place. If, however, it does not readily accept or release the stem freely, begin turning the outer sleeve clockwise in quarter turn increments until a proper setting is reached.

Offset Pulling Head (F1076): After accomplishing steps 1 thru 6, thread the internal threads of the offset pulling head's draw bolt onto the male thread of the adapter puller shaft. Take two or three turns before engaging the male threads of the pulling head housing. How thread both into place until there is no gap between the housing and the draw bolt. Now tighten jam nut.

CAUTION: If you tighten the outer sleeve too far down, it will restrict the return of the draw bolt, thereby causing an overload condition on the tool. The red indicator light will come on. Remove the battery immediately, loosen outer sleeve, and restart assembly procedure. Failure to relieve condition can damage the tool.

Pulling Head Assembly Diagram

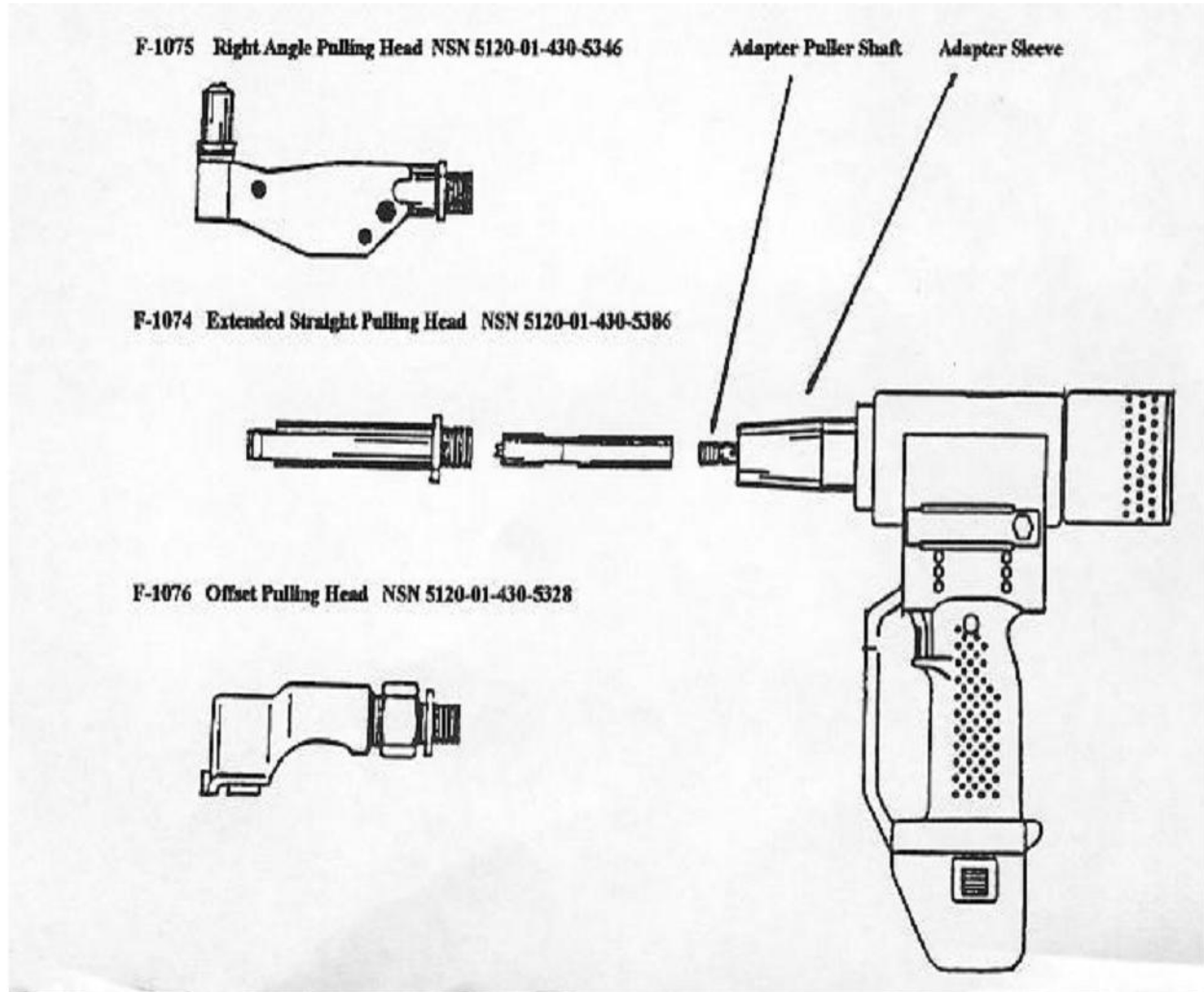

PT-3000-MIL-1
CORDLESS BLIND RIVETER
NSN 5130-01-373-9384

CONTRACTOR: 64878

Fastening Systems International, Inc.
1206 East MacArthur Street
P.O. Box 1372
Sonoma, California 95476
Tel: (707) 935-1170
Fax: (707) 935-1828
Toll Free: (800) 344-2393
E-mail: Sales@fsirivet.com
Web: <http://www.fsirivet.com>

Kit Contents:

Quantity	Part No.	Description
1	PT-3000	Cordless Blind Riveter
1	F-3000 (5130-01-398-4700)	Battery Charger
2	F-3001 (5130-01-398-4699)	12 Volt Battery Pack
1	F187-1A *	Adapter Sleeve, CherryMax
1	F187-2A *	Adapter Shaft Assembly
1	F687-1A	Adapter Sleeve, Olympic Lok
1	F687-2A	Adapter Shaft, Olympic Lok
1	F3123	Jaws, 3pcs
1	F3245	Jaw Follower, 3/16MS & 1/4 CM
1	F140	Nosepiece, 3/32 Nutplate
1	F159 (5120-01-430-5351)	Nosepiece, 1/8 CherryMax
1	F156 (5120-01-430-5384)	Nosepiece, 1/8MS-5/32
1	F143 (5120-01-430-5344)	Nosepiece, 3/16 CherryMax
1	F142 (5120-01-430-5368)	Nosepiece, 1/4 CherryMax
1	F168	Nosepiece, 3/16 Monobolt
1	F580	Nosepiece, 3/16 MS 20600
1	F702	Spare Parts Canister
1	F3602	Metal Carrying Case

* F187-1A and F187-2A sold as an assembly F187 (5120-01-430-5339).

NOTE: Replacement jaws for riveter, 2pc - F122-A (5120-01-430-5378).

**PT-3000-MIL-2
CORDLESS BLIND RIVETER
KIT CONTENTS**

CONTRACTOR: 64878

Fastening Systems International, Inc.
1206 East MacArthur Street
P.O. Box 1372
Sonoma, California 95476
Tel: (707) 935-1170
Fax: (707) 935-1828
Toll Free: (800) 344-2393
E-mail: Sales@fsirivet.com
Web: <http://www.fsirivet.com>

Kit Contents:

<u>Quantity</u>	<u>Part No.</u>	<u>Description</u>
1	PT-3000	Cordless Blind Riveter
1	F-3000 (5130-01-398-4700)	Battery Charger
2	F-3001 (5130-01-398-4699)	12 Volt Battery Pack
1	F-187-1A *	Adapter Sleeve, CherryMax
1	F-187-2A *	Adapter Shaft Assembly
1	F3123	Jaws, 3pcs
1	F3245	Jaw Follower, 3/16MS & 1/4 CM
1	F140	Nosepiece, 3/32 Nutplate
1	F159 (5120-01-430-5351)	Nosepiece, 1/8 CherryMax
1	F156 (5120-01-430-5384)	Nosepiece, 1/8MS-5/32
1	F143 (5120-01-430-5344)	Nosepiece, 3/16 CherryMax
1	F142 (5120-01-430-5368)	Nosepiece, 1/4 CherryMax
1	F168	Nosepiece, 3/16 Monobolt
1	F580	Nosepiece, 3/16 MS 20600
1	F1074 (5120-01-430-5386)	Ex. Straight Head, CherryMax
1	F1075 (5120-01-430-5346)	Rt. Angle Head, CherryMax
1	F1076 (5120-01-430-5328)	Offset Head, CherryMax
1	F702	Spare Parts Canister
1	F3602	Metal Carrying Case

* F187-1A and F187-2A sold as an assembly F187 (5120-01-430-5339).
NOTE: Replacement jaws for riveter, 2pc - F122-A (5120-01-430-5378).