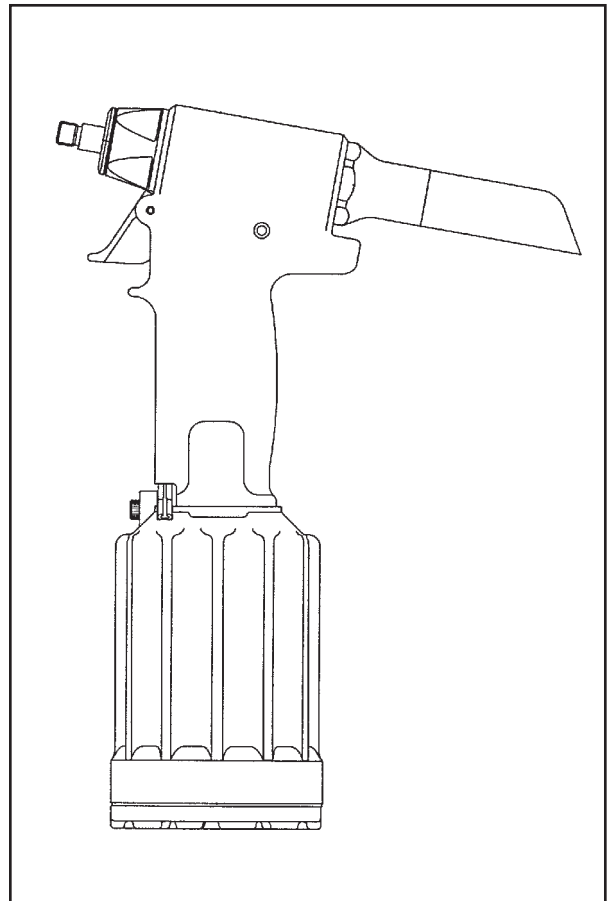


Alcoa  
Fastening  
Systems



*INSTRUCTION MANUAL*  
**2013 AND 2014**  
***ALL MODELS***  
*PNEUDRAULIC INSTALLATION TOOL*



Makers of Huck®, Marson®, Recoil®  
Brand Fasteners, Tools & Accessories

01-23-2006  
HK978



# EU Declaration of Conformity

**Manufacturer:**

Huck International Inc., Installation Systems Division, 85 Grand Street, Kingston, NY, 12401, USA

**Description of Machinery:**

Model number 201 family of fastener installation tools

**Relevant provisions complied with:**


Council Directive related to Machinery, (89/392/EEC), (91/368/EEC), (93/44/EEC), (93/68/EEC)

**European Representative:**

Rob Pattendon, Huck International, Ltd. Unit C Stafford Park 7, Telford Shropshire TF3 3BQ, England, United Kingdom

**Authorized Signature/date:**

I, the undersigned, do hereby declare that the equipment specified above conforms to the above Directive(s) and Standard(s).

Signature: 

Full Name: Renno Budziak

Position: Vice President of Engineering, Installation Systems Division

Place: Kingston, New York, USA

Date: November, 1995

## **Huck Model 201 (family) Sound Level**

SEL --- 75.7 dB (A)  
peak value = 104.4 dB (C)

For an eight hour work day, installing 3000 typical Huck fasteners will result in an equivalent noise level (Leq) of 65.9 dB (A).

To calculate equivalent noise level for other quantities of fasteners in an eight hour period, use the formula:

$$\text{Leq} = \text{SEL} + 10 \log (n/28,800)$$

where n = number of fasteners in eight hours.

## **Huck Model 201 (family) Vibration Level**

For an eight hour work day, installing 3000 typical Huck fasteners will result in an equivalent weighted RMS vibration level (Aeq) of 12.25m/s<sup>2</sup>.

To calculate the equivalent vibration level for other quantities of fasteners in an eight hour period, use the formula:


$$\text{Equivalent Vibration Level, Aeq (rn/s}^2\text{)} = (n/480) \times 1.96$$


where n = number of fasteners in eight hours, and 1.96 (m/s<sup>2</sup>) = Aeq for 60 seconds


# SAFETY


*This instruction manual must be read with particular attention to the following safety guide lines, by any person servicing or operating this tool.*

## 1. Safety Glossary

 — Product complies with requirements set forth by the relevant European directives.

 — Read manual prior to using equipment.

 — Eye protection required while using this equipment.

 — Hearing protection required while using this equipment.



**WARNINGS - Must be understood to avoid severe personal injury.**

**CAUTIONS** - show conditions that will damage equipment and or structure.

**Notes** - are reminders of required procedures.

**Bold, Italic type and underlining** - emphasizes a specific instruction.

2. Huck equipment must be maintained in a safe working condition at all times and inspected on a regular basis for damage or wear. Any repair should be done by a qualified repairman trained on Huck procedures.
3. Repairman and Operator must read manual prior to using equipment and understand any Warning and Caution stickers/labels supplied with equipment before connecting equipment to any primary power supply. As applicable, each of the sections in this manual have specific safety and other information.
4. See MSDS Specifications before servicing the tool. MSDS Specifications are available from you Huck representative or on-line at [www.huck.com](http://www.huck.com). Click on Installation Systems Division.
5. When repairing or operating Huck installation equipment, always wear approved eye protection. Where applicable, refer to ANSI Z87.1 - 1989
6. Disconnect primary power source before doing maintenance on Huck equipment.
7. If any equipment shows signs of damage, wear, or leakage, do not connect it to the primary power supply.
8. Make sure proper power source is used at all times.
9. Never remove any safety guards or pintail deflector.
10. Never install a fastener in free air. Personal injury from fastener ejecting may occur.
11. When using an offset nose always clear spent pintail out of nose assembly before installing the next fastener.
12. If there is a pinch point between trigger and work piece use remote trigger. (Remote triggers are available for all tooling).
13. Do not abuse tool by dropping or using it as a hammer. Never use hydraulic or air lines as a handle. Reasonable care of installation tools by operators is an important factor in maintaining tool efficiency, eliminating downtime, and in preventing an accident which may cause severe personal injury.
14. Never place hands between nose assembly and work piece.
15. Tools with ejector rods should never be cycled with out nose assembly installed.
16. When two piece lock bolts are being used always make sure the collar orientation is correct. See fastener data sheet of correct positioning.

# CONTENTS

<b>EU DECLARATION OF CONFORMITY</b> .....	<b>2</b>
<b>SAFETY</b> .....	<b>3</b>
<b>CONTENTS</b> .....	<b>4</b>
<b>DESCRIPTION</b> .....	<b>5</b>
<b>SPECIFICATIONS</b> .....	<b>5-7</b>
<b>PRINCIPLE OF OPERATION</b> .....	<b>8</b>
<b>PREPARATION FOR USE</b> .....	<b>9</b>
<b>OPERATING INSTRUCTIONS</b> .....	<b>10</b>
<b>SERVICING THE TOOL</b>	
Maintenance .....	<b>10-11</b>
Preventive Maintenance .....	<b>11</b>
Disassembly .....	<b>12-13</b>
Assembly .....	<b>14-15</b>
Sub-assembly Parts List .....	<b>15</b>
Fill and Bleed .....	<b>16-18</b>
How to Measure Stroke .....	<b>19</b>
Assembly Drawing .....	<b>20-30</b>
<b>ACCESSORIES</b> .....	<b>30</b>
<b>TROUBLESHOOTING</b> .....	<b>31</b>
<b>SERVICE NOTES</b> .....	<b>32</b>

# DESCRIPTION

The Model 2013 and 2014 series tools are light-weight, high speed production tools designed to install:

-04 through -06 diameter HUCK-CLINCH® including oversize HUCK-CLINCH.

-04 through -05 diameter UNIMATIC® blind rivets.

Any other blind fasteners having a pinbreak of 2650 lbs or less. The 2013V, with vacuum boost selector switch ON, has two functions:

1. With tool in any position, vacuum holds fastener firmly in nose assembly.
2. Vacuum expels broken pintail into pintail collector.

Pulling action of the pull piston is provided by a pneumatic-hydraulic (pneudraulic) intensifier system powered by 90 psi air pressure. The air inlet is equipped with a connector with 1/4-18 female pipe threads to accept your air hose or quick connect fitting. The piston return stroke is spring actuated.

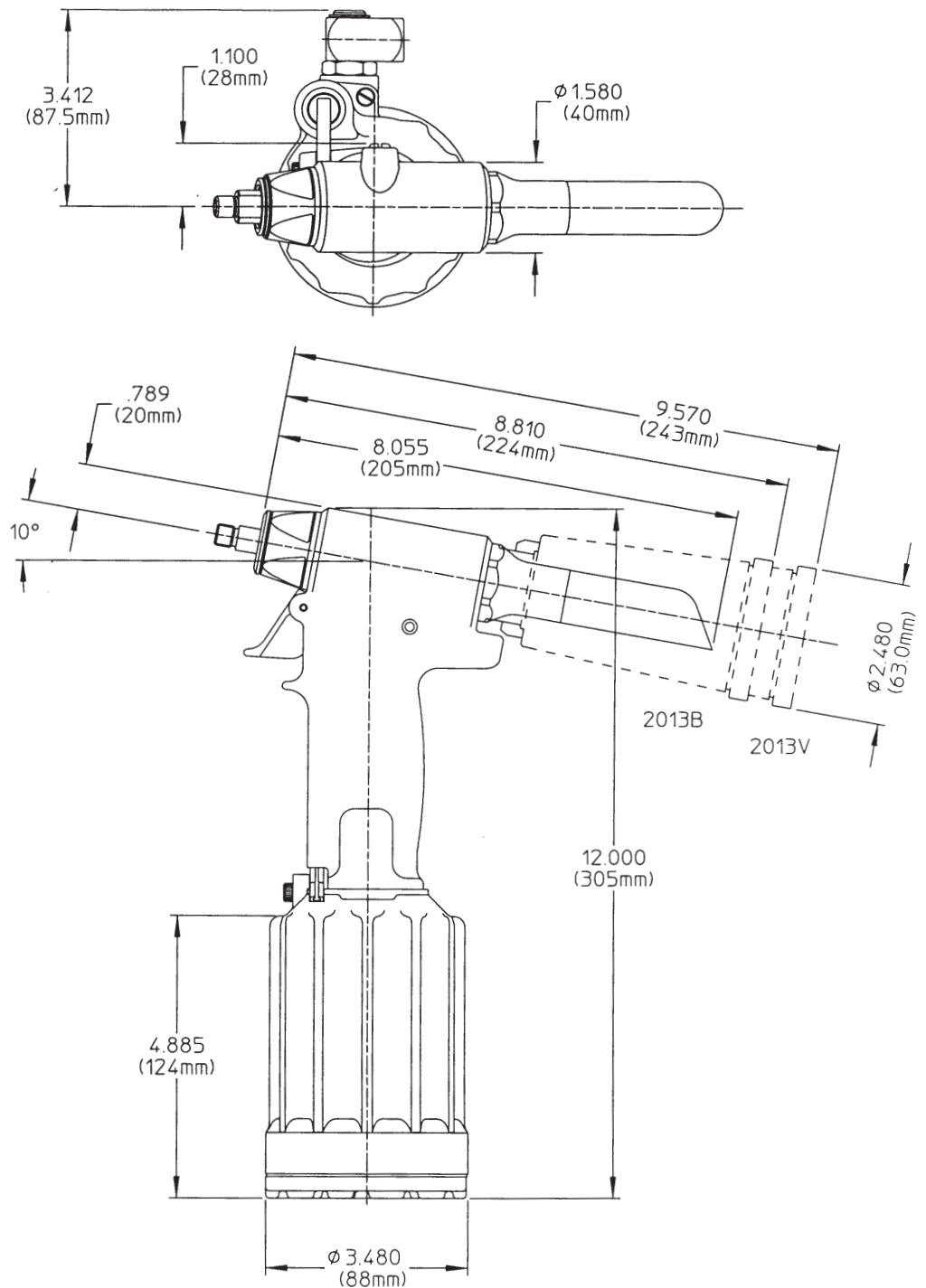
# SPECIFICATIONS

- Min. Stroke: .650
- Air Pressure: 90 psi
- Speed/Cycles: 20 per minute
- Air Consumption: 2.9 CFM
- Weight of 2013 and 2014: 4.4 lbs
- Weight of 2013B & 2013V: 4.7 lbs
- Min. Capacity: 2670 lbs ~ 90 psi

**Fasteners installed:** Consult your Huck representative or available FASTENER SELECTION CHARTS.

**Hydraulic Fluid:** Automatic Transmission Fluid, DEXRON III, or equivalent.

Fig. 1.1

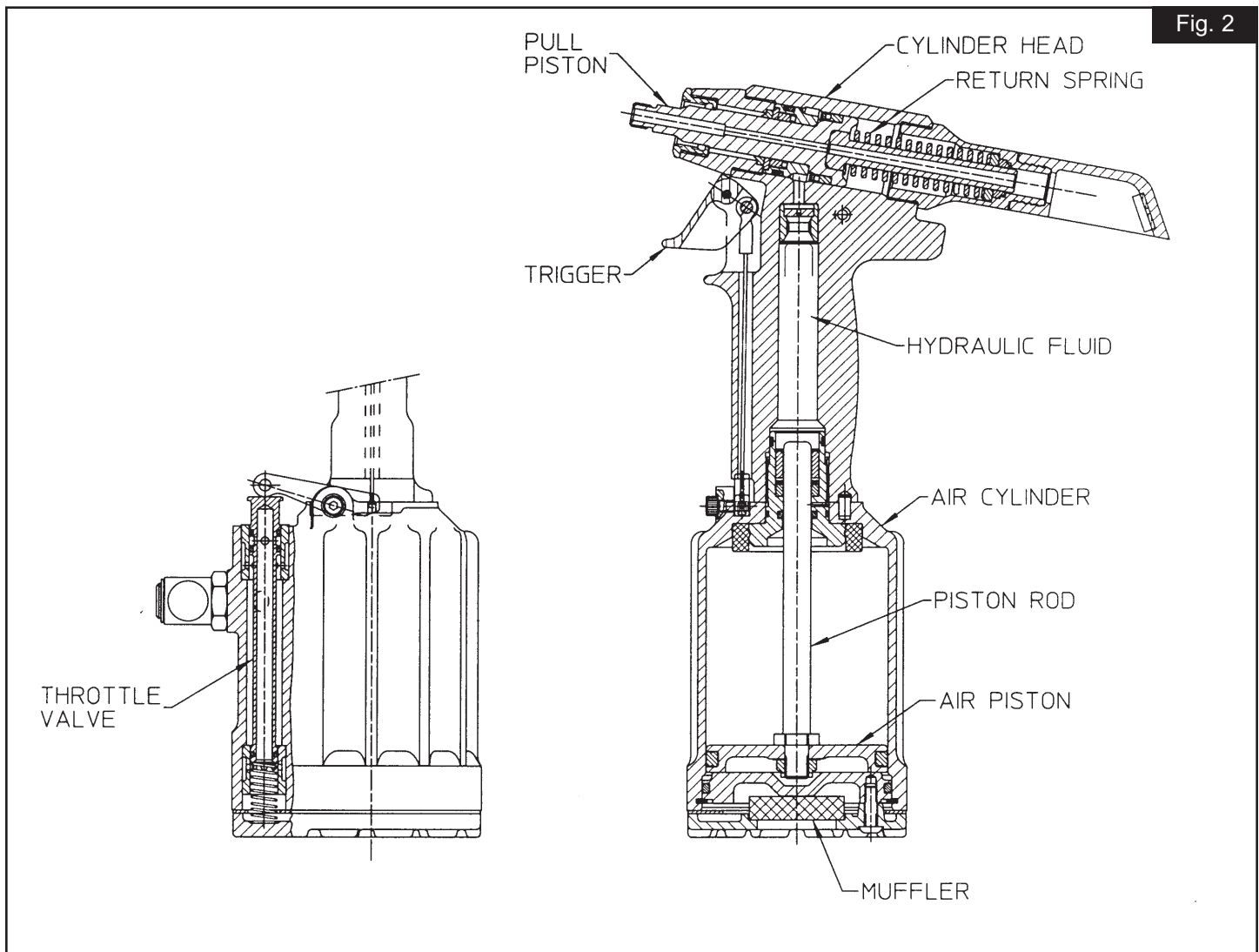


Outline Dimensions

# PRINCIPLE OF OPERATION

When tool is connected to air supply, air pressure holds throttle valve in the up position - - air pressure is directed to the top of piston keeping it down. Depressing trigger moves throttle valve to the down position - - air is directed to the bottom of the piston moving it upward. Air from above piston is exhausted downward thru the throttle valve and exits the muffler at bottom of the tool. The air piston rod is a hydraulic piston which forces pressurized fluid into the cylinder head - - pull piston moves rearward. The nose, which is connected to the pull piston, will install the fastener during the rearward piston movement.

When fastener installation is completed, and upon trigger release, air pressure causes throttle valve to return to its up position - - air flow reverses. The air piston and rod move down to their starting position, exhausting air from below the piston through the muffler at bottom of tool. As rod moves downward and hydraulic pressure is released from pull piston, a spring behind pull piston returns it to its starting position.



**Main Components**

# PREPARATION FOR USE



## **WARNING**

**As applicable, do not use without deflectors or pintail bottles.**

If deflectors are removed or damaged, separated pintails may eject forcibly from rear of tool. Unshielded eyes, especially, may be permanently injured. Other severe injuries can be caused by flying pintails. If there is any chance of a projectile-like ejection, always point rear of tool in a safe direction, or be sure there is some structure that will stop ejecting pintails.



## **WARNING**

To avoid pinch points, be sure there is adequate clearance for tool and operator's hands before proceeding. Tool moving toward structure may crush hands or fingers between tool and structure if clearance is limited.

The 2013 and 2014 are shipped with a plastic plug in the air inlet connector. Connector has 1/4-18 female pipe threads to accept the hose fitting. Quick connect fittings and 1/4 inch inside diameter air hose are recommended. An air supply of 90-100 psi, capable of 2.9 CFM, must be available. Air supply should be equipped with a filter-regulator-lubricator unit.

1. Remove plastic plug from air inlet connector and drop in a few drops of Automatic Transmission Fluid, DEXRON III, or equivalent.
2. Screw quick-connect fitting into air inlet connector.
3. Set air pressure on regulator to 90-100 psi.
4. Attach optional air hose, part number 115436 (supplied with tool), to air inlet connector.
5. Connect air hose to tool.
6. Cycle tool a few times by depressing and releasing trigger.
7. Disconnect air hose from tool.
8. Remove retaining nut.
9. Select correct nose assembly from the available SELECTION CHARTS or speak with your Huck representative.

## **NOTE:**

Quick disconnect fittings and air hoses are not available from Huck.



# OPERATING INSTRUCTIONS



**NOTE:** 2013V is sold with the ribbed vacuum control ON/OFF slide in the forward or OFF position. See *FIGURE 10* for slides location which is shown in the ON (rear) position. While tool is not being used, move slide to the OFF (forward) position to prevent unnecessary air loss.

## Blind Fastener Installation:

The fastener may be placed either in the work hole or in the end of the nose assembly. In either case, tool and nose assembly must be held against work and at right angles to it. Depress trigger and hold it depressed until fastener is installed and pintail breaks. Release trigger.



## WARNINGS

**Inspect tool for damage before each use. Do not operate if damaged as severe personal injury may occur.**

**Broken pintails eject from deflector with speed and force - - be sure pintail deflector is directed safely away front operator or the personnel in the area. Ejecting pintails striking anyone may cause serious personal injury. For Models 2013B and 2013V, pintail bottles must always be used. Replace damaged pintail deflectors and bottles as serious personal injury may occur from pintails when using these defective parts.**

# MAINTENANCE



## Good Service Practice

Service Kits, 2013KIT, 2013BKIT, 2013VKIT, and 2014KIT include perishable parts and should be on hand at all times. Other components, as experience dictates, should also be kept for replacements.

## **ALWAYS REPLACE O-RINGS AND BACK-UP RINGS WHEN TOOL IS DISASSEMBLED FOR ANY REASON.**

The efficiency and life of any tool depends upon proper maintenance and good service practices. Tool should be serviced by personnel who are thoroughly familiar with it and how it operates.

A clean, well-lighted area should be available for servicing the tool. Special care must be taken to prevent contamination of pneumatic and hydraulic systems. Proper hand tools and soft materials to protect tools must be available, Use only standard

hand tools, brass drift and wood block. Vise with soft jaws should be available. Unsuitable hand tools will cause installation tool damage. All parts must be handled carefully and examined for damage and/or wear. Components should be disassembled and assembled in a straight line without bending, cocking or undue force. Disassembly and assembly procedures outlined in this manual should be followed. If Huck recommended procedures are not followed, the tool may be damaged.

Rub SLIC-TITE TEFLON\* thread compound, or equivalent, on pipe plug threads and quick connect fitting.

**CAUTION: Do not use TEFLON tape on pipe threads. Pipe threads may cause tape to shred resulting in tool malfunction. (SLIC-TITE is available in stick form, as 503237, from Huck.)**

# MAINTENANCE (CONT.)

Smear LUBRIPLATE 130AA\*, or equivalent lubricant, on O-rings and mating surfaces to aid assembly and to prevent damage to O-rings. (LUBRIPLATE 130AA is available in a tube, as 502723, from Huck.)

Use VIBRA-TITE\* or equivalent on Gland Housing Assem., 116134-1, threads. Torque to 75-80 ft. lbs.

Apply LOCKTITE\* #271 Adhesive/sealant to Locknut, 505420. (LOCKTITE is available from Huck, in a tube, as 503657.) Torque to 25-30 ft. lbs.

- \* TEFLON is a trademark of E.I. DuPont de Nemours & Co.
- \* LOCTITE is a trademark of Loctite Corp.
- \* TRUARC is a trademark of Waldes Kohinoor, Inc.

- \* VIBRA-TITE is a trademark of the Oakland Corporation.
- \* LUBRIPLATE is a trademark of Fiske Brothers Refining Co.

## Standard Tools Available from Huck

1/8 hex key, 502294, used on button head screw, 504127.

5/32 hex key, 502295, used on socket cap screw, 123756.

(0400) TRUARC pliers, 502866, used on (N5100-I00) retaining ring.

# PREVENTIVE MAINTENANCE



## Tool Maintenance

The 2013 and 2014 series require a minimum amount of maintenance. Regular inspection and correction of minor problems will keep the tool operating efficiently and prevent downtime.

Using filter-regulator-lubricator unit is highly recommended for safe and reliable tool operation. If a filter-regulator-lubricator unit is not being used in the air supply: (1) remove hose fitting from air inlet connector and drop in a few drops of automatic transmission fluid or light oil (2) blow out air line to remove dirt and water before connecting air hose to tool. At regular intervals, depending upon use, replace all seals in tool. Service Kits should be kept on hand. Inspect both hydraulic pistons, and their piston rods for scored surfaces, excessive wear or damage, and replace as necessary.

**Always replace seals and back-up rings when tool is disassembled for any reason to assure proper sealing and tool function.**

## Nose Assembly Maintenance

### **Caution**

**Damaged jaw teeth, or debris packed between teeth, will result in failure to install fastener or improperly installed fastener.**

Frequently cleaning the nose assembly is recommended. Remove nose assembly from tool and disassemble - - see DISASSEMBLY Check components for any signs of damage, e.g. cracks, scores and spring damage. Check gripper teeth for damage. Remove any debris packed between teeth with a sharp pointed 'pick'. Periodically dip nose, while cycling tool, in mineral spirits, isopropyl alcohol or other suitable solvent, to clean jaws and wash away metal chips and dirt.

# DISASSEMBLY



Refer to *MAINTENANCE: GOOD SERVICE PRACTICE, FIGURES 4, 5, 6, 7, 8, 9, 10, 11, and 12.*



## **WARNING**

**Air hose must be disconnected before:**

- **Removing or attaching nose assembly.**
- **Cleaning tool and/or nose assembly.**
- **Replacing worn or damaged tool components.**

**Tool may be activated if not disconnected and cylinder is under pressure. Fingers may be severely pinched/lacerated. Other severe personal injury may result.**

The following procedure is for complete disassembly - - disassemble only subassemblies necessary to check and replace damaged or worn seals, wipers, back-up rings and other components.

**Always replace seals, wipers, and back-up rings of disassembled sub-assemblies.**

1. Disconnect tool from air source.
2. Unscrew Retaining Nut and remove nose assembly.
3. Unscrew Bleed Plug, including O-ring, from top of Handle/head. Turn tool over and allow fluid to drain into container - - tool may be cycled to clear tool more completely. Discard fluid.
4. Pull Pintail Deflector off End Cap.
5. Remove Throttle Arm Pivot Screw and lift out throttle arm. Disconnect ball end of Cable Assembly from throttle arm.
6. Hold tool in vise with bottom up. Remove Button Head Screws (3) with 1/8 hex key.

Remove End Cap and Gasket. Remove Muffler from end cap. Remove Spring from Throttle Valve.

7. To loosen Cylinder Head Retaining Ring in Cylinder, tap Cylinder Head with mallet. Remove Retaining Ring.
8. **NOTE:** Screw Button Head Screws back into Cylinder Head. Carefully pull or pry on screws to remove head.
9. To remove air piston from cylinder, pull on Lock Nut with VISE-GRIP pliers.

**Note:** Air piston and rod should not be disassembled and reassembled. If lock nut loosens, apply LOCTITE #271 and tighten to 25-30 ft. lbs.

**CAUTION**  
**DO NOT SCRATCH, NICK OR DING PISTON ROD. THIS WILL CAUSE PERMANENT HYDRAULIC LEAKAGE.**

10. Remove Bumper from Gland Assembly. Unscrew gland with 1 3/8 socket wrench and extension bar.
11. Remove SPIRO-LOX Retaining Ring from gland. Pull out Spacer and POLYSEAL.
12. Lift cylinder from handle/head.
13. Turn handle/head over - - drain fluid into container. Discard fluid.
14. Pull Throttle Valve out of cylinder.

**Note:** *Service on Throttle Valve Bushings not normally required.*

# DISASSEMBLY (CONT.)

## **CAUTION**

**ONLY IF AIR LEAKAGE IS NOT CORRECTABLE WITH NEW THROTTLE VALVE SEALS, BUSHINGS SHOULD BE REPLACED IN CYLINDER.**

15. Press out Lower Bushing and Upper Bushing. Use square ended brass rods at least six inches long. With proper diameter rod, press out lower bushing first, and then, press out upper bushing using a larger diameter rod.
16. **For 2013 and 2014:** Place handle/head securely in vise. Remove End Cap with 15/16" open end wrench. Extract Spring, Washer and Wiper Seal.  
**For 2013B or 2013V:** see Special Disassembly Instructions on this page.

## **CAUTION**

**If Piston Seals and Gland Seals must be reused, help prevent damaging them at disassembly by installing OPTIONAL POLYSEAL Insertion/removal Tool (121694-202) in rear of Handle/head.**

## **REMOVAL OF PISTON AND FRONT GLAND** - - see Fig. 12

17. Thread POLYSEAL Insertion/removal Tool, 121694-202, into Handle/head.
18. **For 2013 Series Only:** Thread Piston Assembly Tool, 123111-5 onto piston.
19. Push complete piston from front using brass drift. Allow clearance, with stand-off, for piston as it leaves tool.
20. Remove Piston Assembly Bullet, Spacer and POLYSEAL Insertion/removal Tool.  
**NOTE:** Inspect hydraulic piston for wear, scoring or damage. Replace when necessary.
21. Unscrew Adapter with wrench.
22. Inspect all seals and parts.
23. Remove trigger cable assembly by driving pin with punch. Remove dowel pin to disconnect cable from trigger.

## **Special Disassembly Instructions for 2013B and 2013V**

1. Place handle/head securely in vise. Use 0100 TRUARC pliers, 502857, to remove retaining ring - - reach through window of pintail bottle. Remove washer.
2. Remove pintail bottle.
3. Remove bottle adapter and vacuum ON/OFF slide.
4. Remove end cap assembly and spring.
5. Remove washer and O-ring from spring side of end cap.
6. Remove retaining ring on bottle side of end cap. Remove spacer, wiper seal, washer and O-ring.
7. Remove O-rings from ON/OFF slide.

# ASSEMBLY



See *MAINTENANCE: GOOD SERVICE PRACTICE. FIGURES 3, 4, 5, 6, 7, 8, 9, 10, 11 and 13.*

Clean all components with mineral spirits, and inspect for wear or damage. Replace as necessary.

## **CAUTION**

**Always replace all seals, wipers and back-up rings on/in disassembled components. These parts wear from friction and deteriorate with age - replacement prevents potential leakage.**

Use seals, wipers and back-up rings supplied in *SERVICE KIT, 2013KIT, 2013BKIT, 2012VKIT and 2014KIT* -see NOTES. Smear LUBRIPLATE 130AA or PARKER-O-LUBE on seals.

1. ***If Bushings have been removed from cylinder:***  
Use an arbor press and apply LOCTITE #609, (503377) on bushings before being pressed into cylinder. Place chamfered end of Upper Bushing In top of Cylinder. Carefully press bushing squarely into cylinder. Repeat procedure for Lower Bushing.
2. Assemble Gland Assembly - - see *FIGURE 5.1.*  
  
*NOTE: Cup of POLYSEAL must face toward top of tool when installed in Gland.*  
  
Replace POLYSEAL, Spacer and SPIRO-Lox Retaining Ring.
3. Install Adapter into cylinder handle/bead.
4. Thread POLYSEAL Insertion/removal Tool, 121694-202, into handle/head.
5. **For 2013 Series Only:** Thread Piston Assembly (bullet) Tool, 123111-5, onto piston assembly.
6. Push front gland assembly onto piston, as shown.
7. Slide wiper onto piston, as shown.
8. Push assembled components in gently from rear of tool using a press, or a soft mallet and wood or brass drift.
9. **For 2013 Series Only:** Remove Piston Assembly (bullet).  
**For 2013 and 2014:** Remove POLYSEAL Insertion/removal Tool.
10. **For 2013 and 2014:** Assemble Spring, Spacer, Rear Wiper Seal and End Cap into handle/head.  
**For 2013B or 2013V:** reverse the disassembly instructions in the Special Disassembly Instructions for 2013B and 2013V; in the Disassembly section.
11. See *FIGURE 4* - - position Cable Assembly in Trigger slot and push Dowel Pin through holes in trigger and cable assembly. Position assembled trigger in handle and drive Pin through holes in handle and trigger.
12. Hold handle/head in vise with lower end pointing up. Turn cylinder bottom up, and position on handle by lining up cylinder pin with handle hole.
13. Apply VIBRATITE or equivalent to threads of Gland Assembly. Screw gland into head/handle. Using 1 3/8 socket wrench, tighten gland to 75-80 ft. lbs.



# ASSEMBLY (CONT.)

## Sub-assembly Part Numbers and Notes

Refer to illustrations

- |  |   |   |  |
|--|---|---|--|
| 15. Lubricate piston rod. Press assembled air piston/piston rod into cylinder just enough to allow installation of cylinder head.                      | 1 | 123775<br><br>(1)<br>500816<br>501110<br>505818<br>122432<br>505817 | Front Gland sub-assembly includes:<br>Front Gland Housing<br>O-ring<br>back-up ring<br>POLY-SEAL<br>Gland Cap<br>wiper                             |
| 16. Push Cylinder Head squarely into cylinder taking care not to damage O-ring. Install spiral Retaining Ring. Align screw holes with muffler end cap. | 2 | 123774-4<br>(1)<br>506160<br>506654<br>506653                       | Piston sub-assembly includes:<br>Piston<br>POLY-SEAL<br>flat washer<br>external retaining ring   |
| 17. Position Muffler in center of cylinder head. Position Gasket on cylinder.  |   |   |  |
| 18. Carefully position Muffler End Cap on cylinder - - be certain that muffler is properly positioned in recess of muffler end cap.                    | 3 | 123777-2<br><br>(1)<br>501451<br>111803-1<br>506493<br>505420       | Air Piston and Rod sub-assembly includes:<br><br>QUAD ring<br>Piston Rod<br>flat washer - - .38 ID; .751 OD<br>self-locking nut - - .38-24 thin SS |
| 19. Muffler end cap is secured with three Button head Screws - tighten with 1/8 hex key.   |   |   |  |
| 20. Place tool upright on level surface. Drop Spring into throttle valve bore in cylinder. Push Throttle Valve into cylinder.                          | 4 | 104293<br><br>(1)<br>505438   | Bleed Plug sub-assembly includes:<br>Bleed Plug<br>O-ring  |
| 21. Place ball end of Throttle Cable in end of Throttle Arm.   | 5 | 123778-1  | Cylinder Head sub-assembly includes:<br>Cylinder Head<br>O-ring  |
| 22. Slide Throttle Arm into slot on Cylinder.  |   |   |  |
| 23. Install Pivot Screw in cylinder to retain throttle arm.  | 6 | 123779-1  | Throttle Valve sub-assembly includes:<br>Throttle Valve<br>O-ring<br>O-ring  |
| 24. Follow <i>FILL AND BLEED PROCEDURE</i> to fill tool - - see appropriate section.   |   |   |  |
| 25. Install Bleed Screw after <i>FILL AND BLEED PROCEDURE</i> .  | 7 |   |  |

### CAUTION

**Install cups of POLY-SEALS positioned as shown; position wipers as shown.**

(1) Purchase sub-assembly when this part (1) is required.

# FILLING AND BLEEDING PROCEDURE



## Equipment Required:

- Shop airline with 90 - 100 psi max.
- Air regulator
- Fill bottle, 120337, (supplied with tool).
- Large flat blade screwdriver
- Nose assembly or optional stall nut
- Fasteners (optional)
- Optional stall nut, 124090  
*Stall nut is used to load tool during bleeding and for measuring stroke.*

## Preparation:

- Install air regulator in airline and set pressure to 20 - 40 psi.
2. Fill bleed bottle almost full of DEXRON III - - ATF (automatic transmission fluid) - - see *FIGURE 3*.

## Procedure to Fill Empty Tool (new or rebuilt) - - as Applicable:

1. Attach the tool air source momentarily to seat air piston at bottom of cylinder -- disconnect tool. With fillport facing up, lay tool on its side.
2. With a screwdriver, remove bleed plug from fillport.

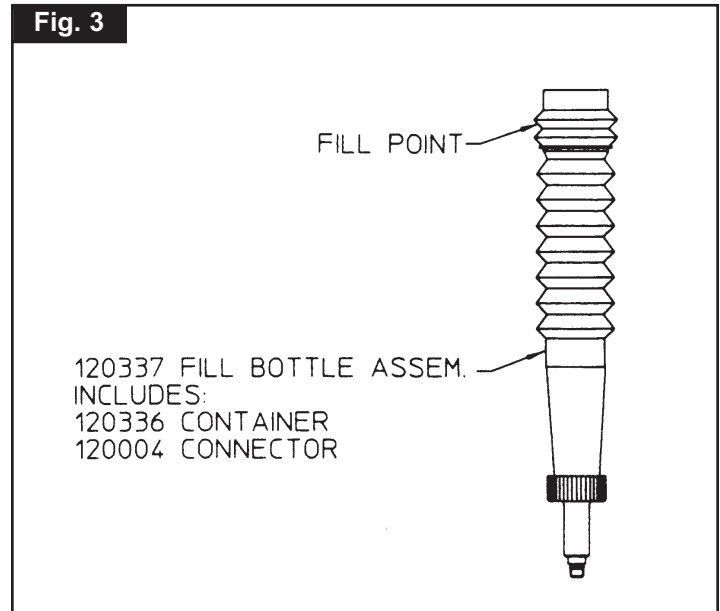


### **WARNING**

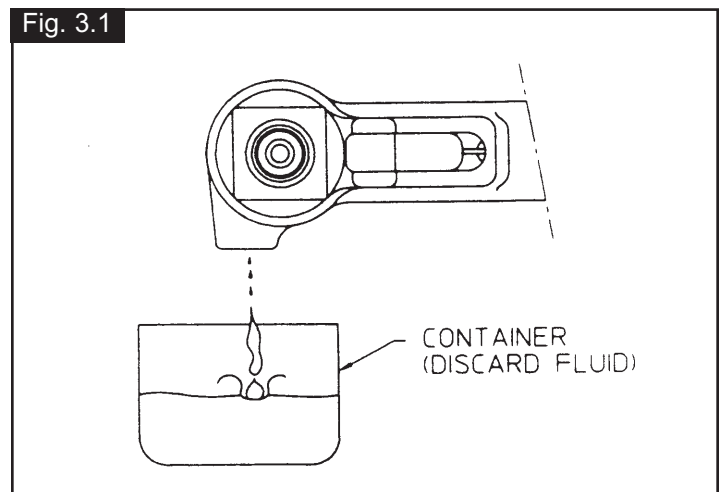
Air pressure ***MUST*** be set to 20 - 40 psi to prevent possible injurious **high pressure** spray. Never cycle tool without bleed plug tightened, fill bottle tightened in tool, or fillport held over a receptacle (see *FIGURE 3.1*). ***When not properly contained any fluid present in tool will spray out. Severe injury may result.***

3. Screw fill bottle into fillport in the head.
4. Set airline pressure to 20-40 psi and

**Fig. 3**

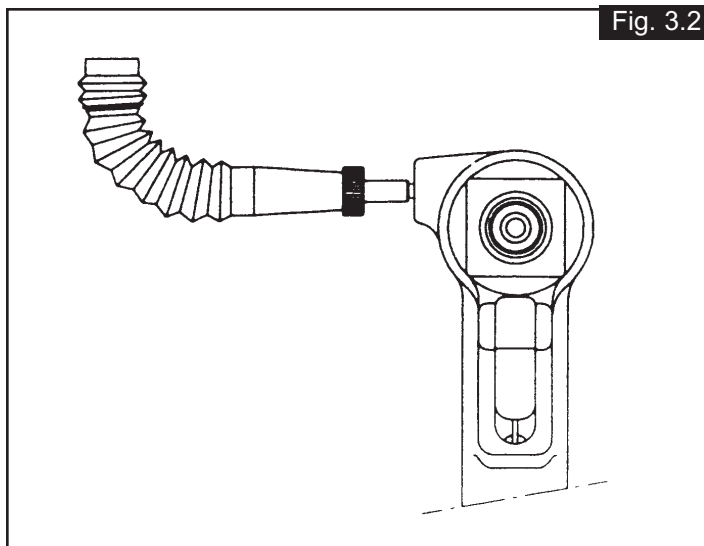


**Fig. 3.1**



## FILLING AND BLEEDING PROCEDURE (CONT.)

- Stand tool upright on bench. While triggering tool slowly (20 - 30 cycles), bend fill bottle at right angles to tool - - see *FIGURE 3.2*. Air bubbles will emerge from tool, When bubbles stop, cycling may be discontinued.

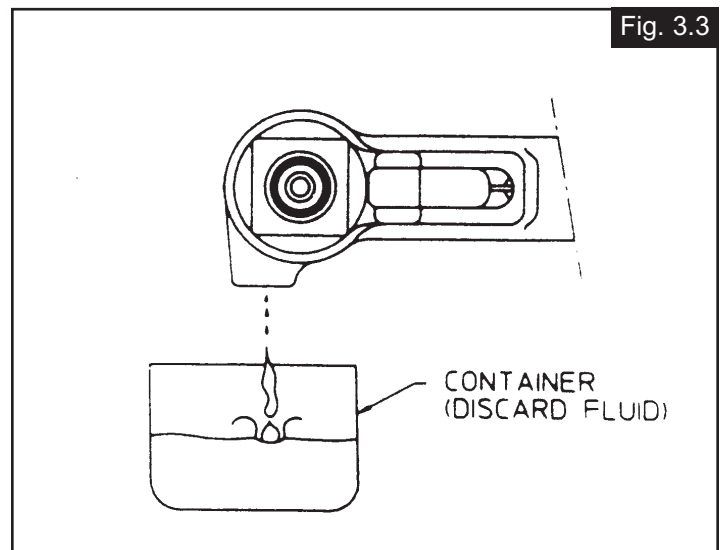


- When trigger is released, pull piston returns to idle position (full forward). Disconnect tool from airline.
- Lay tool on its side. Remove fill bottle. Top off fluid in fillport. Install bleed plug and tighten.
- Connect airline to tool. There is a choice of two procedures for measuring the stroke - - with and without a stall-nut - - see appropriate section and follow the selected procedure. If stroke is less than specified, remove bleed plug and top off fluid. Reinstall bleed plug.
- Increase air pressure to specification. Install two fasteners to check function and installation in a single stroke, or cycle tool with stall-nut fully threaded onto piston to load up tool. Measure stroke again. Remove plug and top off fluid. Reinstall plug and cycle again - - measure again. Continue this process until stroke meets minimum requirements.

### Bleed Procedure for Partially Filled Tool in Field Use - - as Applicable:

- Disconnect tool from airline. With fillport facing up, lay tool on its side.
- Remove bleed plug from bleed port.
- Hold tool over suitable container with fillport facing into container.

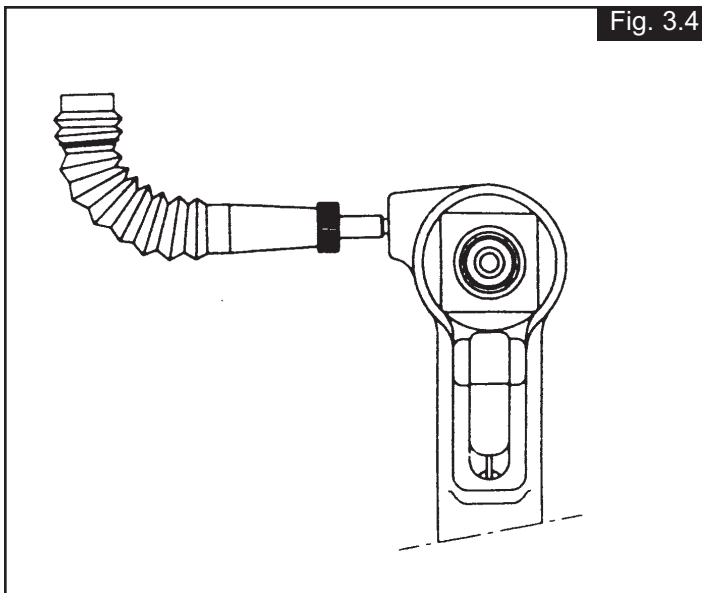
**WARNING**  
 Air pressure ***MUST*** be set to 20 - 40 psi to prevent possible injurious high pressure spray. Never cycle tool without bleed plug tightened, fill bottle tightened in the tool, or the fillport held over a receptacle (see *FIGURE 3.3*). ***When not properly contained any fluid present in tool will spray out. Severe injury may result.***



- Connect tool to airline. Cycle tool several times to drain the old fluid, air and foam.
- Screw fill bottle into fillport.
- See ***WARNING*** above. With air pressure set at 20-40 psi, connect airline to tool.



## FILLING AND BLEEDING PROCEDURE (CONT.)



7. Stand tool upright on bench. While actuating the trigger slowly (20 - 30 cycles), bend fill bottle at right angles to tool - - see *FIGURE 3.4*. Observe that air bubbles emerge from tool. When bubbles are no longer observed, cycling may be discontinued.
8. When trigger is released, pull piston returns to idle position (full forward). Disconnect tool from airline with piston full forward.
9. Lay tool on its side. Remove fill bottle. Top off fluid in fillport. Install bleed plug and tighten with screwdriver.
10. Connect airline to tool. There is a choice of two procedures for measuring the stroke - - with and without a stall-nut - - see appropriate section and follow the selected procedure. If stroke is less than specified, remove bleed plug and top off fluid. Reinstall bleed plug.
11. Install two fasteners to check function and installation in a single stroke, or cycle tool with stall nut fully threaded onto piston. Measure stroke again. Remove plug and top off fluid. Reinstall plug and cycle again - - measure again. Continue this process until stroke meets minimum requirements.

## SERVICE NOTES:

# HOW TO MEASURE STROKE

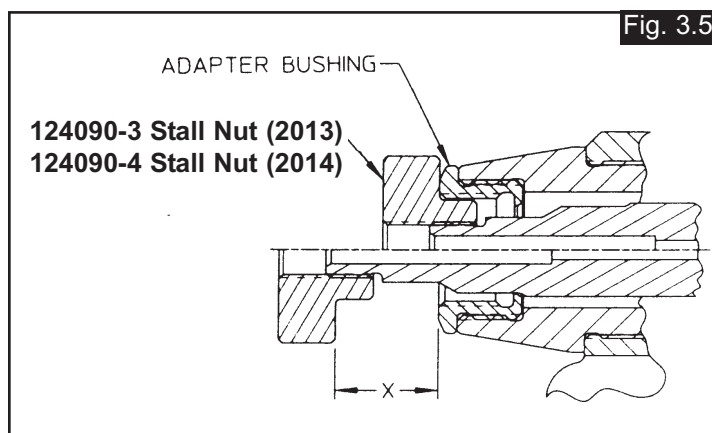


For the 2014 a Stroke Limiter Kit (p/n 126915) is shipped with the tool loose in bag.

## To measure stroke of tool with stall-nut threaded onto piston (nose assembly must be removed for this procedure):

1. Disconnect tool from airline - - remove nose from tool.
2. Reconnect tool to airline. Cycle tool and hold trigger depressed - - this keeps piston fully to the rear and at end of PULL stroke. Thread stall-nut back onto piston until it contacts adapter bushing.
3. Release trigger. Stall-nut will move forward with piston. See FIGURE 3.5 and measure "X" dimension. This is the tool's stroke.

4. If stroke is less than .650, refer to appropriate previous section. Follow filling and topping off instructions.



## To measure stroke of tool without stall-nut (nose assembly must be removed for this procedure):

1. Disconnect tool from airline - - remove nose from tool.
2. Reconnect tool to airline, with piston fully forward (end of RETURN stroke), measure and record "Y" dimension - - see FIGURE 3.6.
3. Hold trigger depressed. Piston is now fully to the rear and at end of PULL stroke. Measure and record "X" dimension.
4. Subtract "X" dimension from "Y" dimension.
5. If stroke is less than 650, refer to appropriate previous section. Follow filling and topping off instructions.

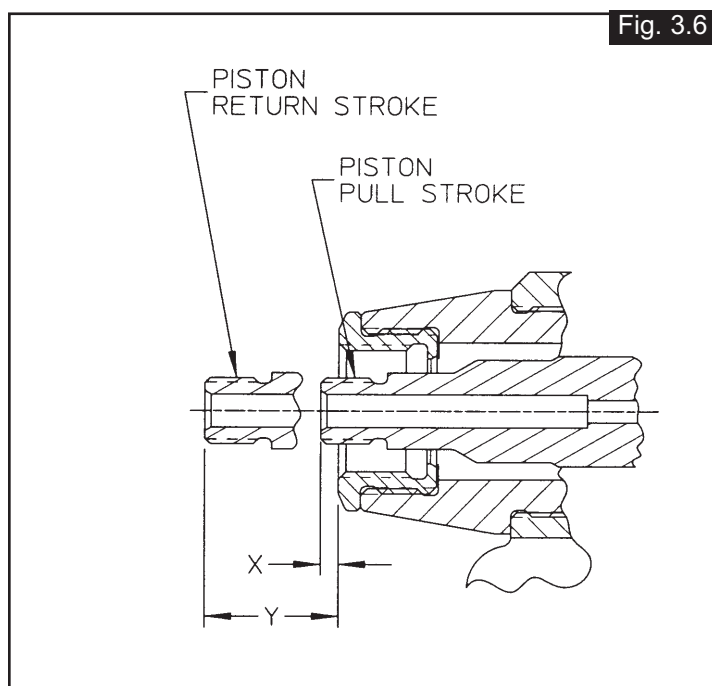
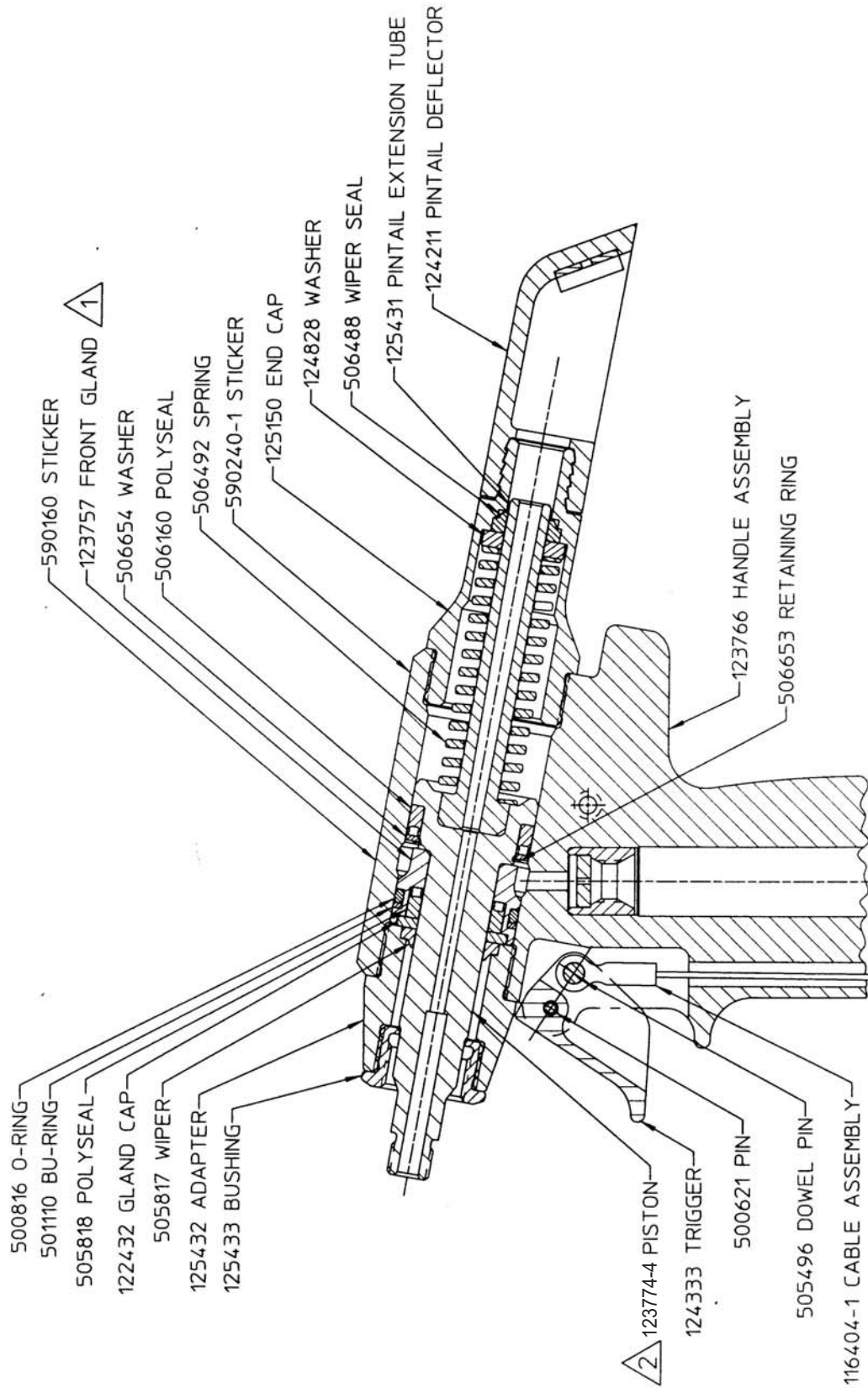
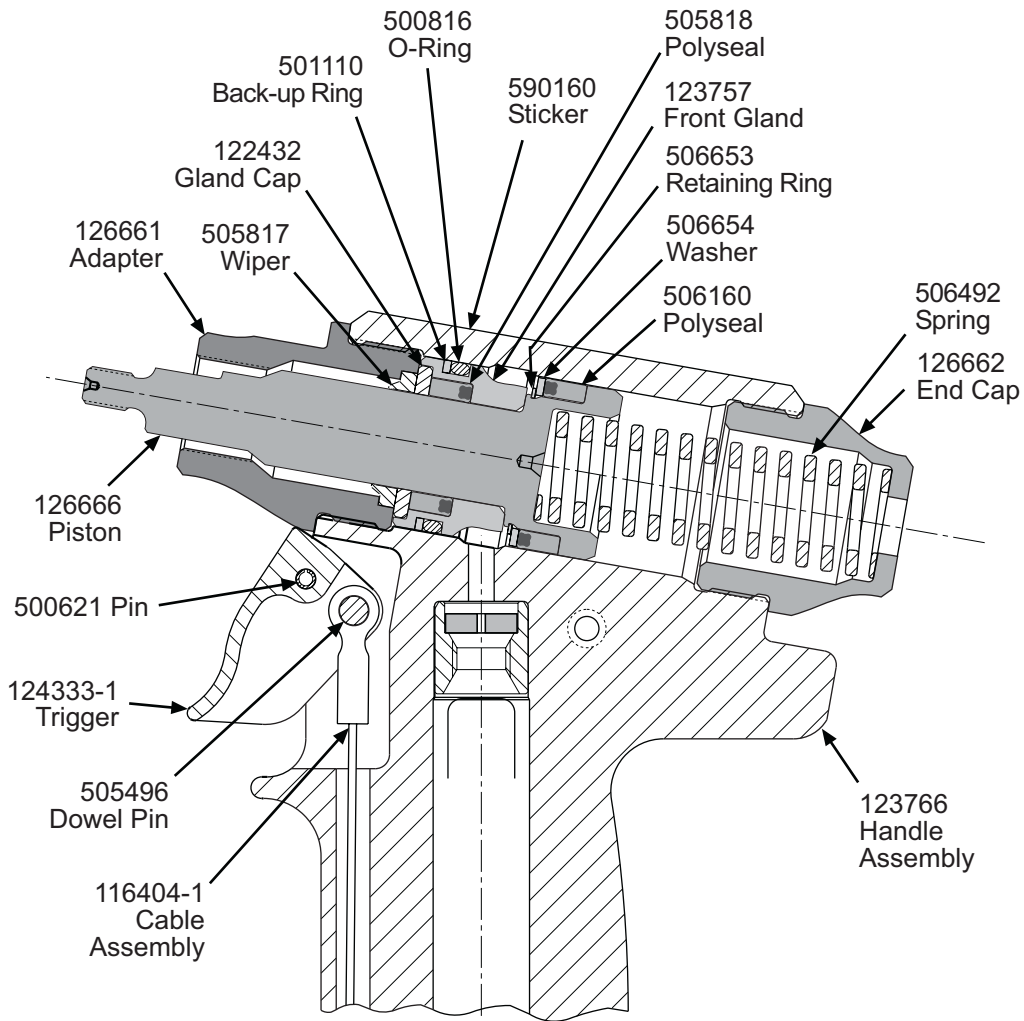


Fig. 4



2013 Series Head/Handle

Fig. 4a



2014 Head/Handle

Fig. 5 & 5.1

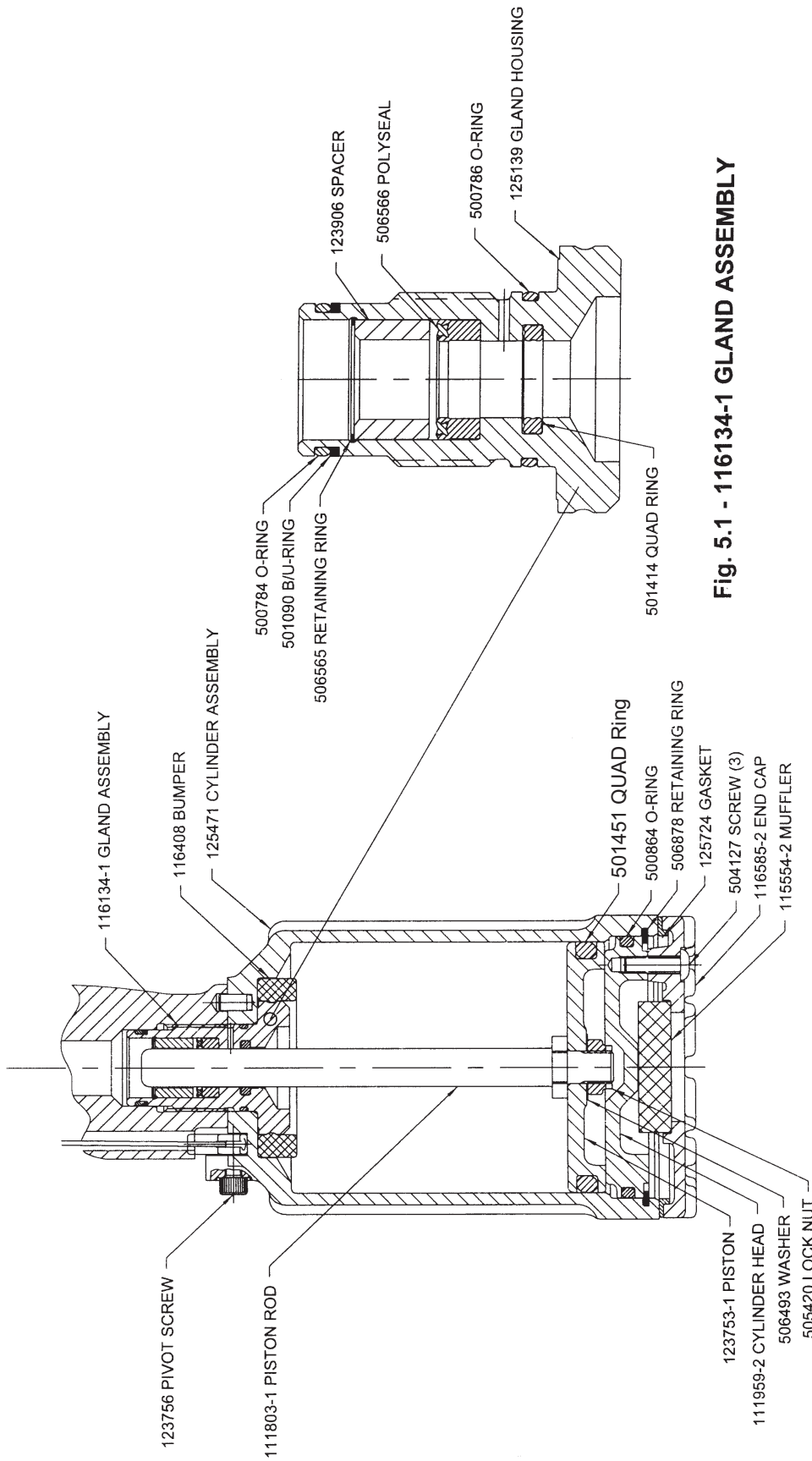
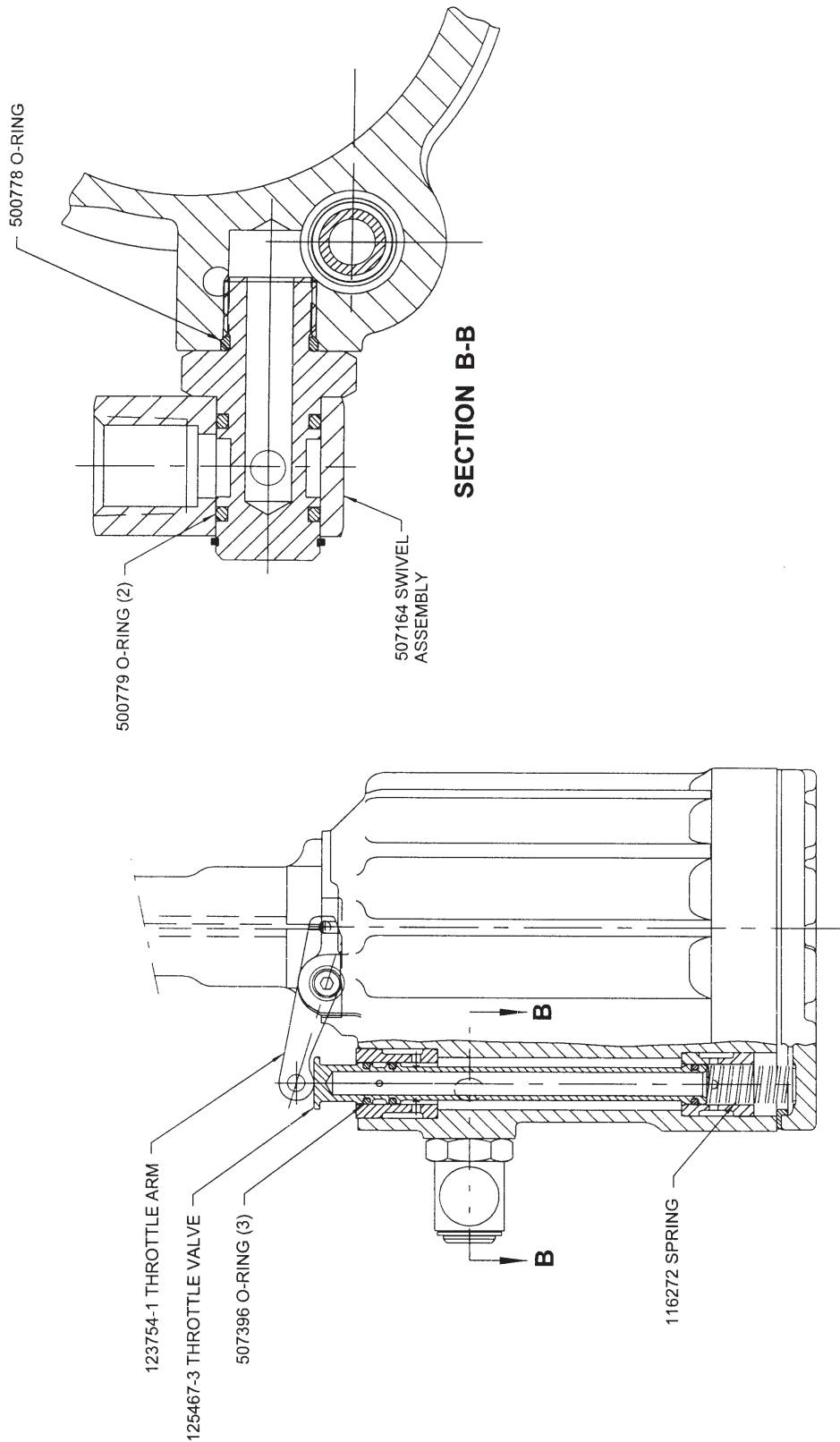


Fig. 5.1 - 116134-1 GLAND ASSEMBLY

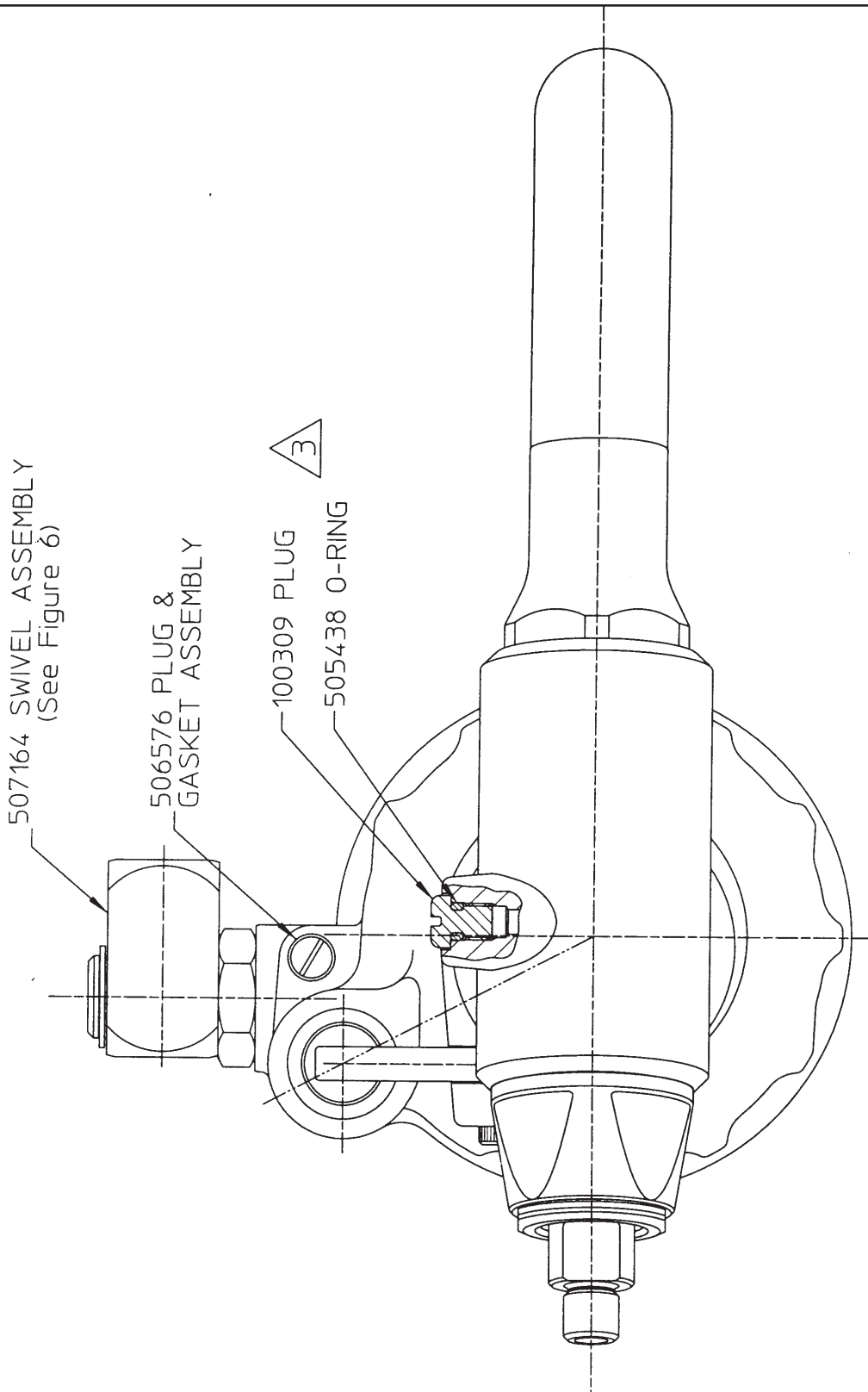
Fig. 5 - 2013 and 2014 Air Cylinder

Fig. 6



Throttle Valve Sub-assembly and Related Components

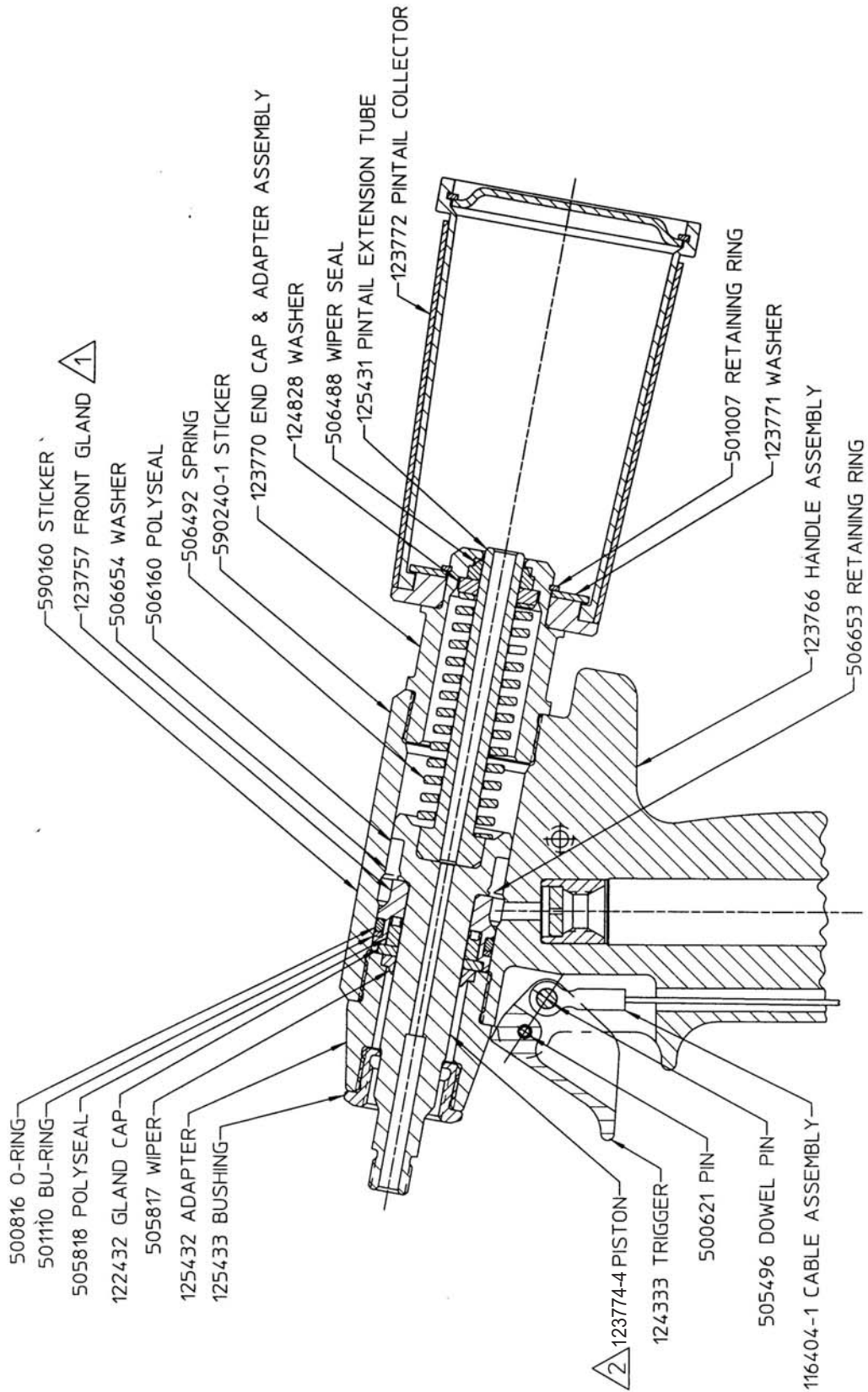
Fig. 7



**Swivel and Swivel Bolt Sub-assembly  
Fill Plug and O-ring Sub-assembly**



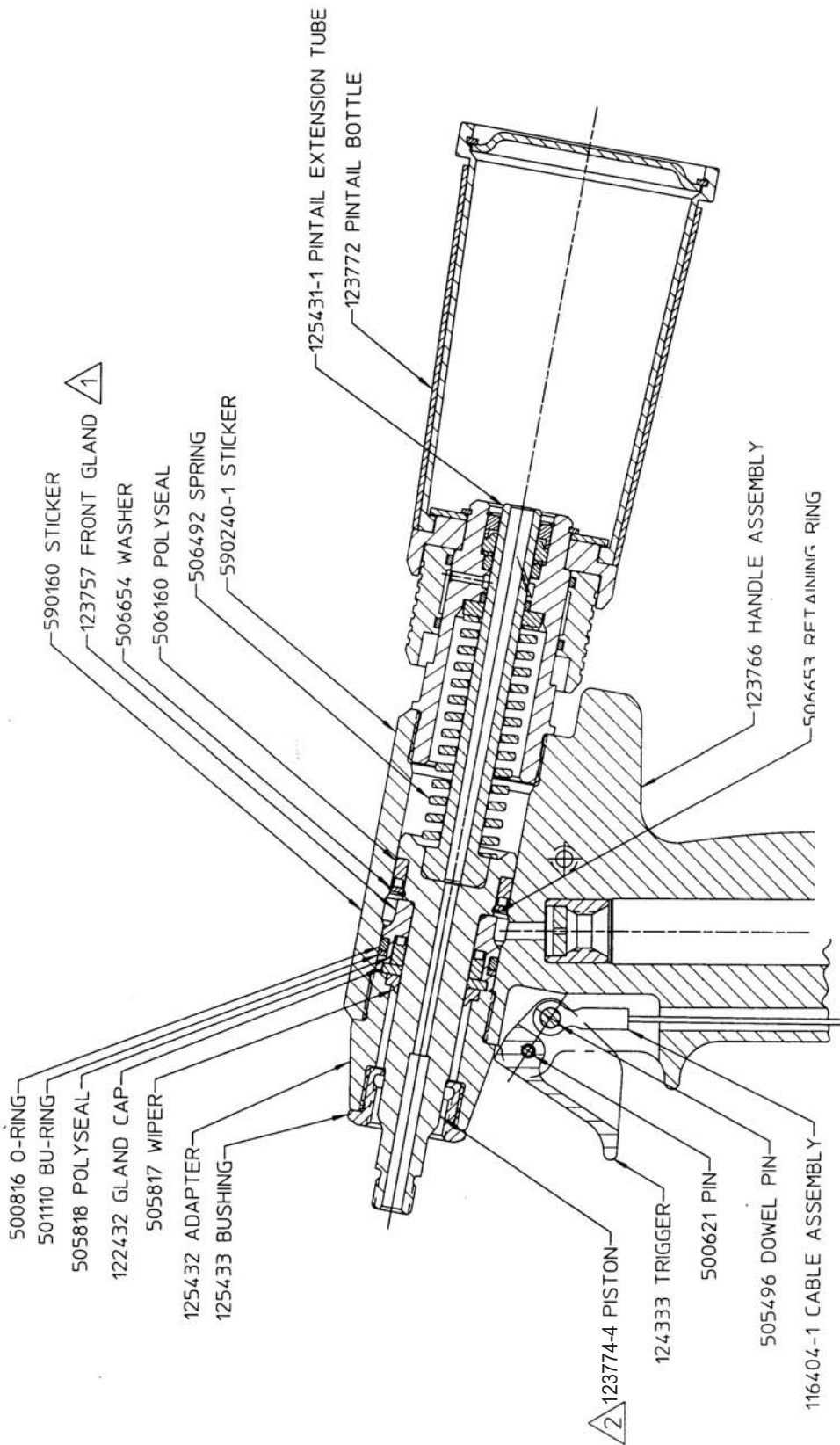
Fig. 8



2013B Head/Handle

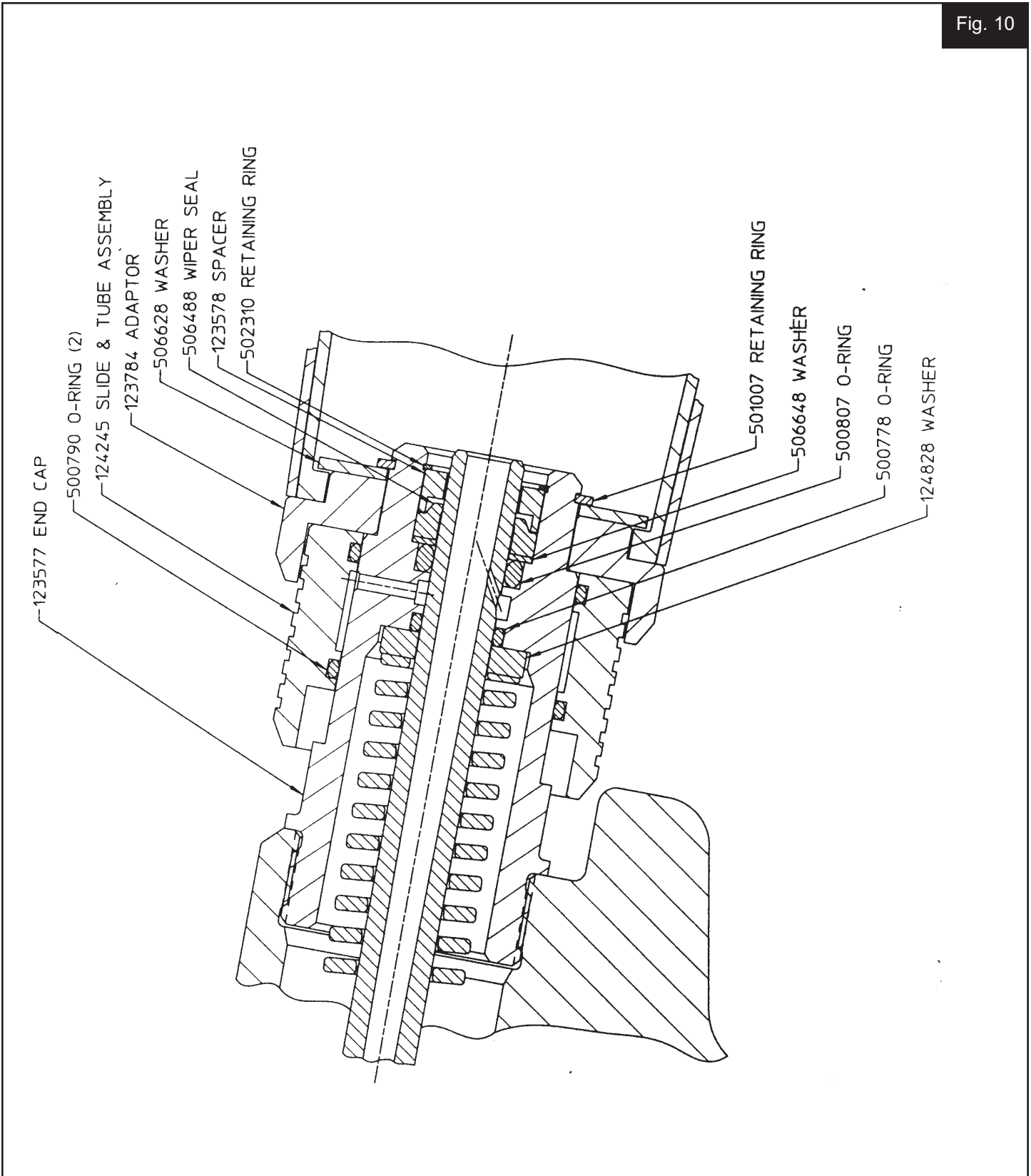


Fig. 9



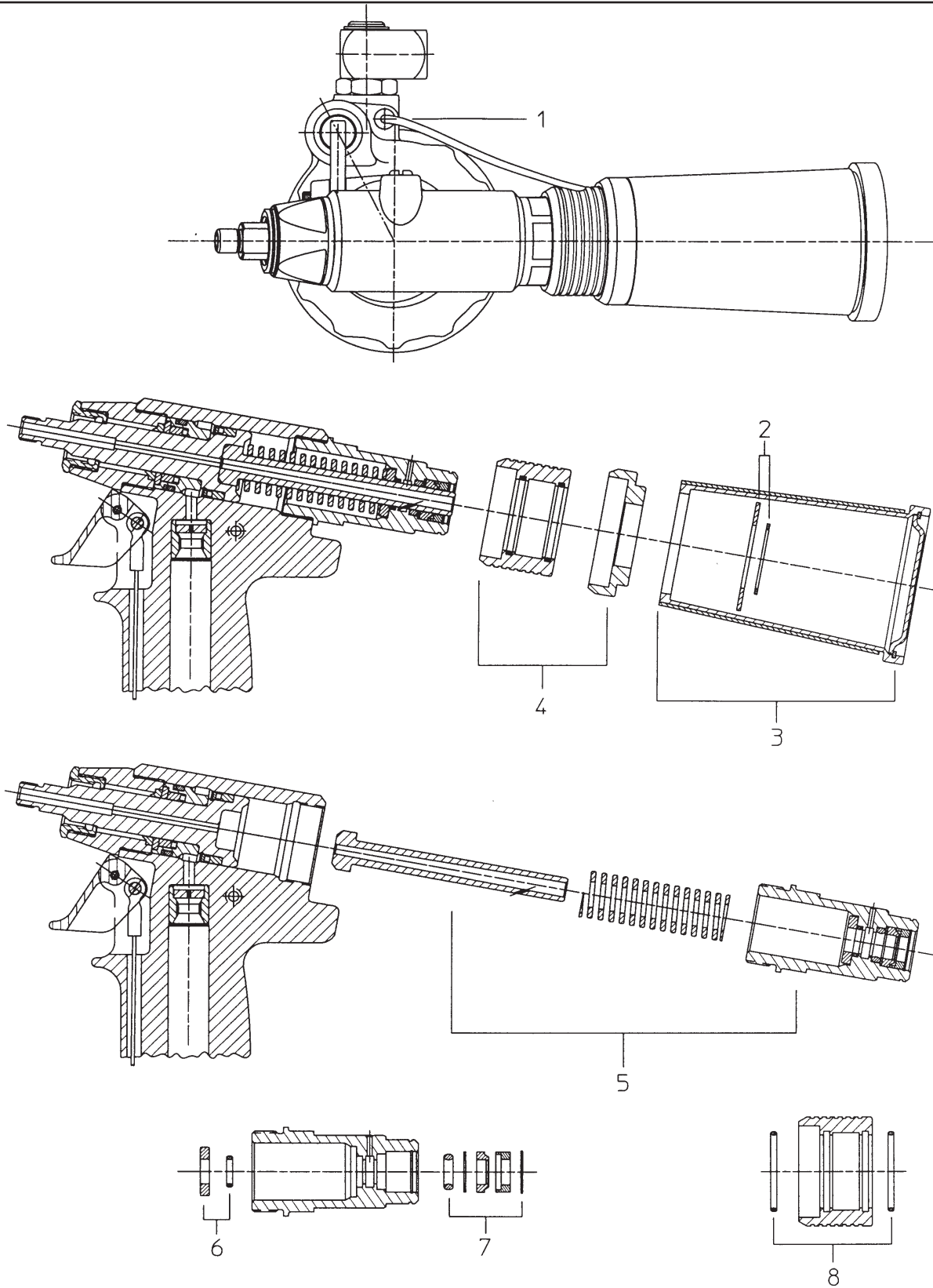
2013V Head/Handle

Fig. 10



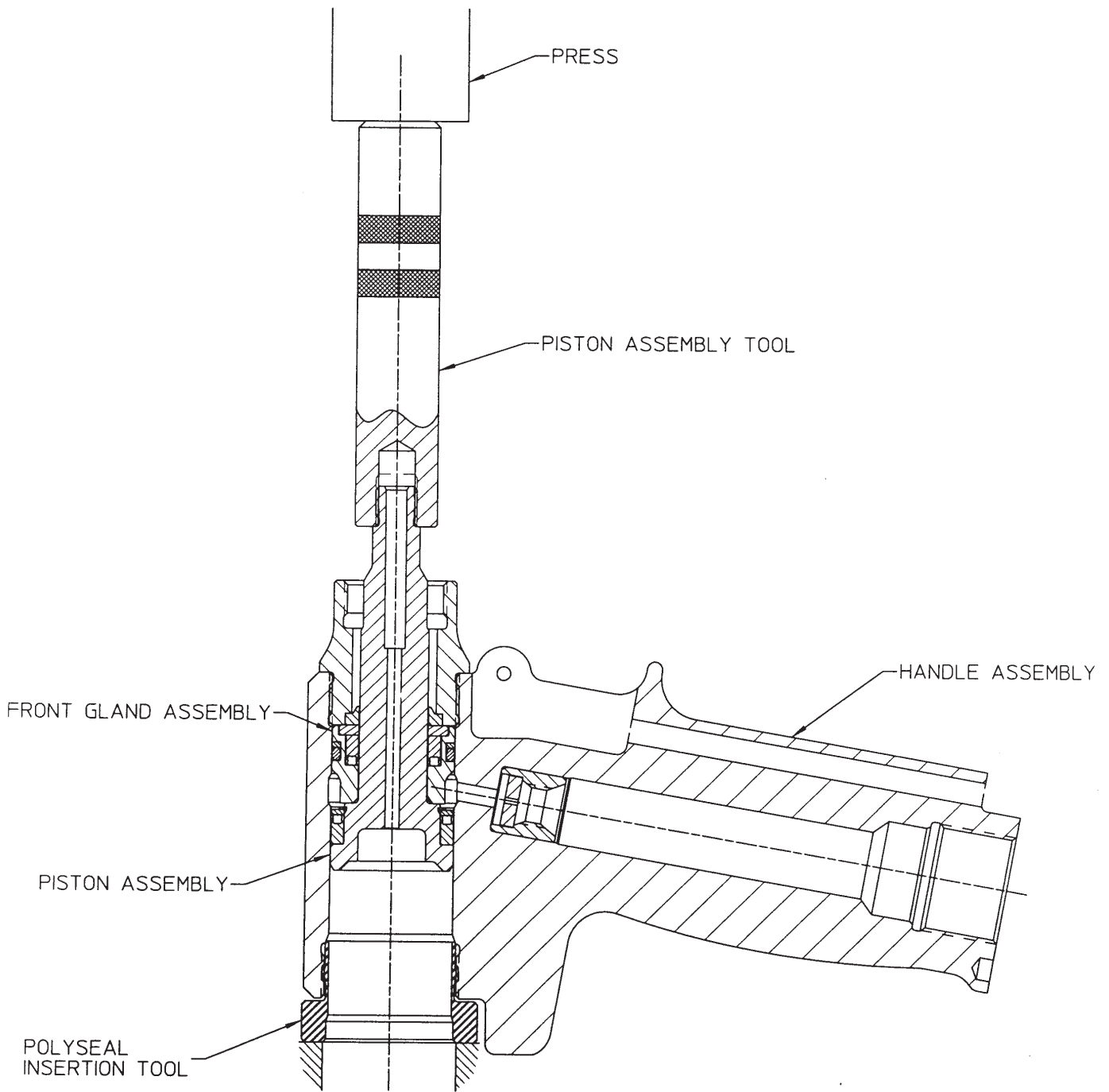
2013V Assembled Vacuum Attachment

Fig. 11



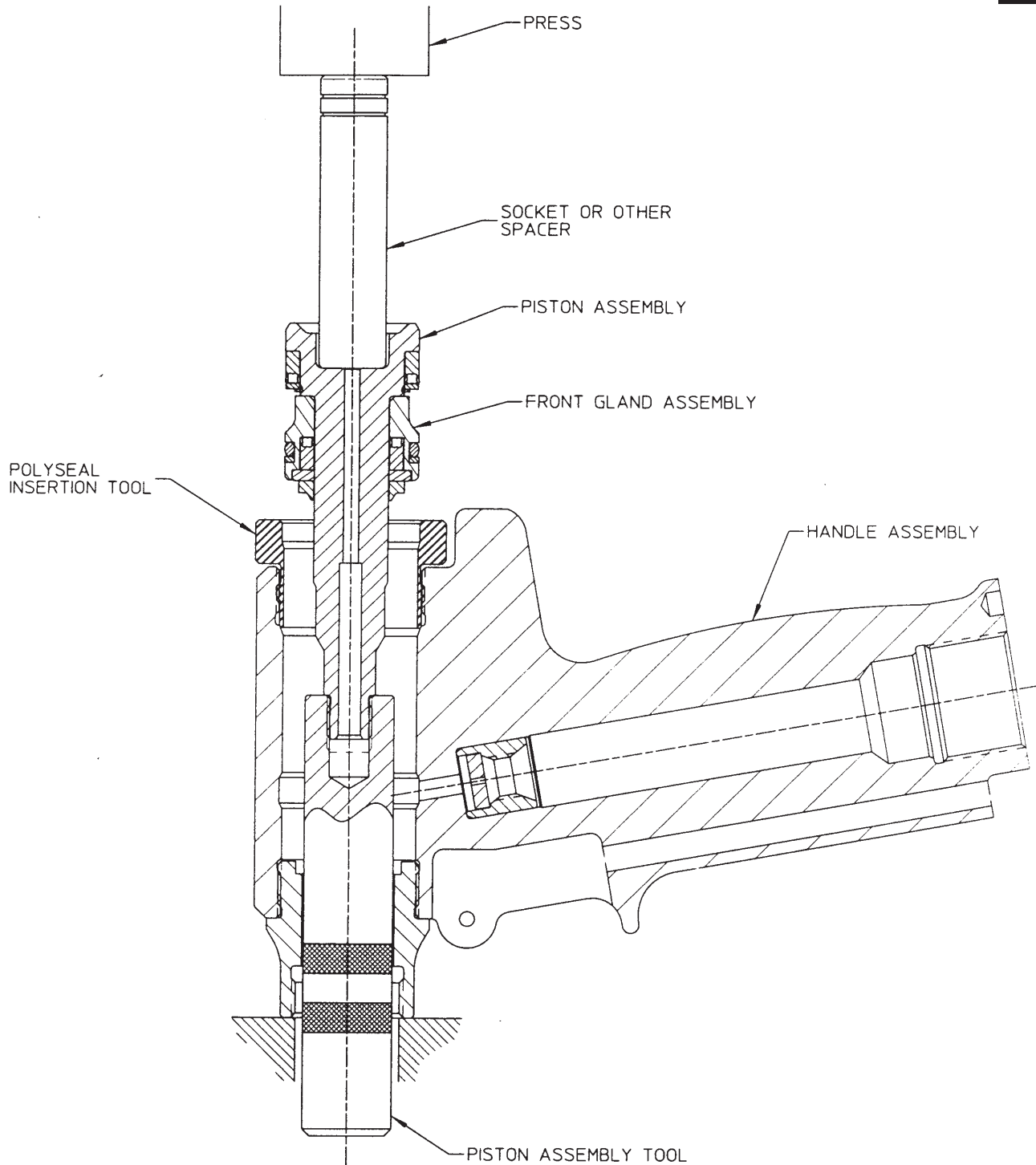
Exploded View Of Vacuum Attachment

Fig. 12



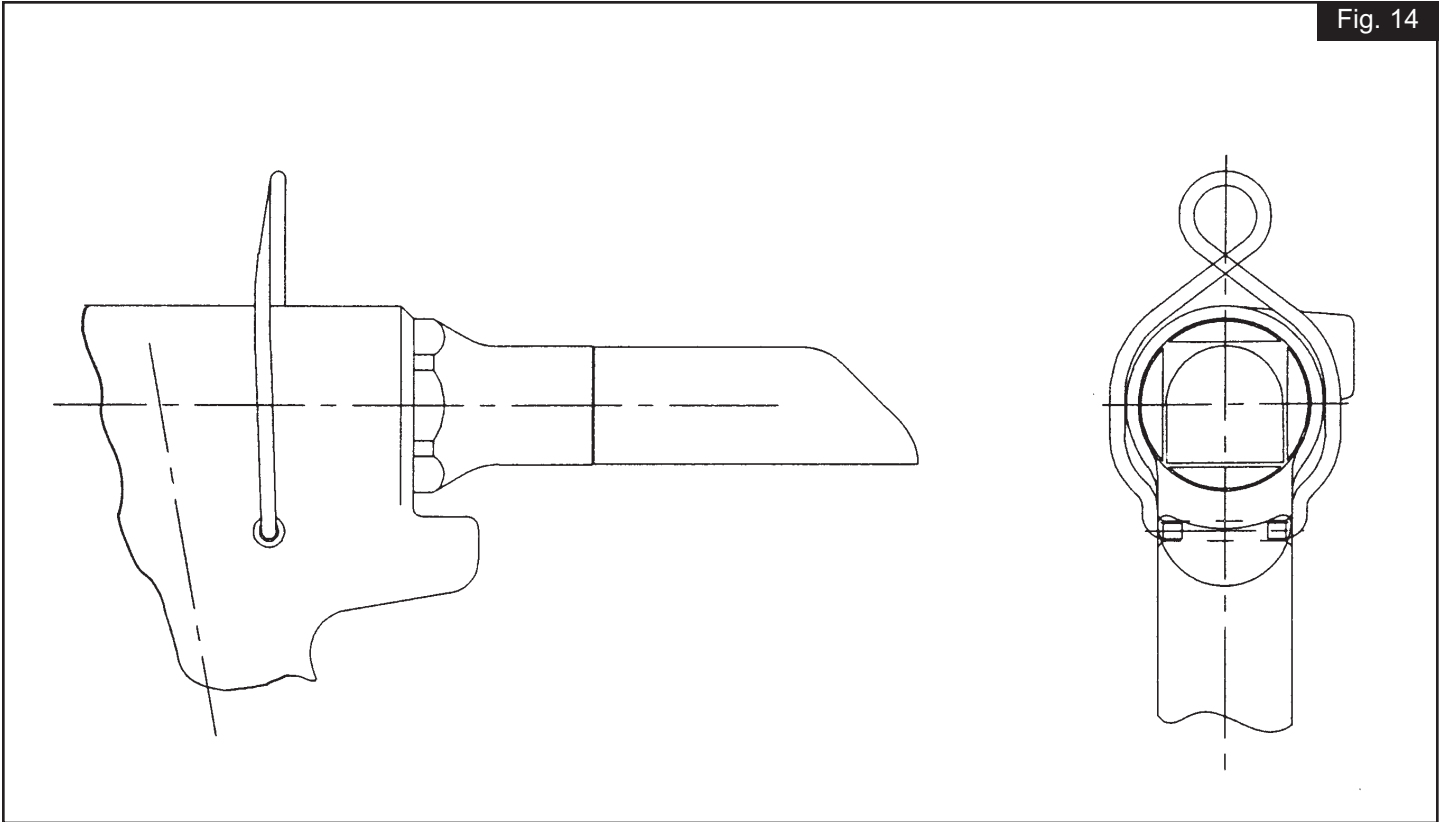
Removing Piston and Front Gland (2013 Series Ony)

Fig. 13



Installing Piston and Front Gland (2013 Series Only)

Fig. 14



2013 and 2014 with Suspension Spring, 124447

## ACCESSORIES

### 2013 Series Accessories

**Assembly Tool Kit, 123110-5**, includes:

- \* POLYSEAL Insertion/removal Tool, 121694-202
- \* Piston Assembly (bullet) Tool, 123111-5

**Stall-nut 124090-3**

**Fill and Bleed Bottle 120337**

**Suspension Spring, 124447**, See *FIGURE 14*.

**Pintail Bag 125652**

### 2014 Series Accessories

**POLYSEAL Insert/removal Tool 121694-202**

**Stroke Limiter Kit (p/n 126915) includes:**

- \*126663 stroke limiter
- \*590463 sticker

**Stall Nut 124090-4**

**Suspension Spring, 124447**, See *FIGURE 14*.

# TROUBLESHOOTING

Always check out the simplest possible cause of a malfunction first. For example, an air hose not connected. Then proceed logically, eliminating each possible cause until the defective part is

located. Where possible, substitute known good parts for suspected bad parts. Use this chart to help locate and correct malfunction:

<u>Symptom</u>	<u>Probable cause</u>
1. Tool fails to operate when triggered.	<ul style="list-style-type: none"> <li>a. Throttle valve O-rings (3) worn or damaged.</li> <li>b. Air pressure too low.</li> <li>c. Throttle cable assembly broken.</li> </ul>
2. Tool does not complete fastener installation or break pintail.	<ul style="list-style-type: none"> <li>a. Air pressure too low.</li> <li>b. Hydraulic fluid low, causing short stroke.</li> <li>c. Air piston QUAD ring worn or damaged.</li> <li>d. Air in hydraulic system - - see <i>FILLING AND BLEEDING</i>.</li> <li>e. Collet backed off from Piston.</li> </ul>
3. Hydraulic fluid exhausts with air.	<ul style="list-style-type: none"> <li>a. Worn or damaged O-rings, POLY-SEAL and/or QUAD ring in Gland Assembly, 116134-1.</li> </ul>
4. Hydraulic fluid leaks at Cylinder Head End Cap.	<ul style="list-style-type: none"> <li>a. Worn or damaged Pull Piston O-ring/back-up ring.</li> </ul>
5. Hydraulic fluid leaks at Pull Piston Rod.	<ul style="list-style-type: none"> <li>a. Worn or damaged Front Gland POLY-SEAL and wiper, and/or O-ring.</li> </ul>
6. Pull Piston will not return.	<ul style="list-style-type: none"> <li>a. Broken or weak Return Spring.</li> <li>b. Collet backed off from Piston.</li> </ul>
7. Air leaks at Air Cylinder Head.	<ul style="list-style-type: none"> <li>a. Cylinder Head O-ring damaged.</li> </ul>

# SERVICE NOTES:



# LIMITED WARRANTIES

**Tooling Warranty:** Huck warrants that tooling and other items (excluding fasteners, and hereinafter referred as "other items") manufactured by Huck shall be free from defects in workmanship and materials for a period of ninety (90) days from the date of original purchase.

**Warranty on "non standard or custom manufactured products":** With regard to non-standard products or custom manufactured products to customer's specifications, Huck warrants for a period of ninety (90) days from the date of purchase that such products shall meet Buyer's specifications, be free of defects in workmanship and materials. Such warranty shall not be effective with respect to non-standard or custom products manufactured using buyer-supplied molds, material, tooling and fixtures that are not in good condition or repair and suitable for their intended purpose.

**THERE ARE NO WARRANTIES WHICH EXTEND BEYOND THE DESCRIPTION ON THE FACE HEREOF. HUCK MAKES NO OTHER WARRANTIES AND EXPRESSLY DISCLAIMS ANY OTHER WARRANTIES, INCLUDING IMPLIED WARRANTIES AS TO MERCHANTABILITY OR AS TO THE FITNESS OF THE TOOLING, OTHER ITEMS, NONSTANDARD OR CUSTOM MANUFACTURED PRODUCTS FOR ANY PARTICULAR PURPOSE AND HUCK SHALL NOT BE LIABLE FOR ANY LOSS OR DAMAGE, DIRECTLY OR INDIRECTLY, ARISING FROM THE USE OF SUCH TOOLING, OTHER ITEMS, NONSTANDARD OR CUSTOM MANUFACTURED PRODUCTS OR BREACH OF WARRANTY OR FOR ANY CLAIM FOR INCIDENTAL OR CONSEQUENTIAL DAMAGES.**

Huck's sole liability and Buyer's exclusive remedy for any breach of warranty shall be limited, at Huck's option, to replacement or repair, at FOB Huck's plant, of Huck manufactured tooling, other items, nonstandard or custom products found to be defective in specifications, workmanship and materials not otherwise the direct or indirect cause of Buyer supplied molds, material, tooling or fixtures. Buyer shall give Huck written notice of claims for defects within the ninety (90) day warranty period for tooling, other items, nonstandard or custom products described above and Huck shall inspect products for which such claim is made.

**Tooling, Part(s) and Other Items not manufactured by Huck.**

**HUCK MAKES NO WARRANTY WITH RESPECT TO THE TOOLING, PART(S) OR OTHER ITEMS MANUFACTURED BY THIRD PARTIES. HUCK EXPRESSLY DISCLAIMS ANY WARRANTY EXPRESSED OR IMPLIED, AS TO THE CONDITION, DESIGN, OPERATION, MER-**

**CHANTABILITY OR FITNESS FOR USE OF ANY TOOL, PART(S), OR OTHER ITEMS THEREOF NOT MANUFACTURED BY HUCK. HUCK SHALL NOT BE LIABLE FOR ANY LOSS OR DAMAGE, DIRECTLY OR INDIRECTLY, ARISING FROM THE USE OF SUCH TOOLING, PART(S) OR OTHER ITEMS OR BREACH OF WARRANTY OR FOR ANY CLAIM FOR INCIDENTAL OR CONSEQUENTIAL DAMAGES.**

The only warranties made with respect to such tool, part(s) or other items thereof are those made by the manufacturer thereof and Huck agrees to cooperate with Buyer in enforcing such warranties when such action is necessary.

Huck shall not be liable for any loss or damage resulting from delays or nonfulfillment of orders owing to strikes, fires, accidents, transportation companies or for any reason or reasons beyond the control of the Huck or its suppliers.

## ***Huck Installation Equipment***

Huck International, Inc. reserves the right to make changes in specifications and design and to discontinue models without notice.

Huck Installation Equipment should be serviced by trained service technicians only.

Always give the Serial Number of the equipment when corresponding or ordering service parts.

Complete repair facilities are maintained by Huck International, Inc. Please contact one of the offices listed below.

### Eastern

One Corporate Drive Kingston, New York 12401-0250  
Telephone (845) 331-7300 FAX (845) 334-7333

### Canada

6150 Kennedy Road Unit 10, Mississauga, Ontario, L5T2J4, Canada.  
Telephone (905) 564-4825 FAX (905) 564-1963

### Outside USA and Canada

Contact your nearest Huck International Office, see back cover.

In addition to the above repair facilities, there are Authorized Tool Service Centers (ATSC's) located throughout the United States. These service centers offer repair services, spare parts, Service Parts Kits, Service Tools Kits and Nose Assemblies. Please contact your Huck Representative or the nearest Huck office listed on the back cover for the ATSC in your area.



For the Long Haul™

## A Global Organization

Alcoa Fastening Systems (AFS) maintains company offices throughout the United States and Canada, with subsidiary offices in many other countries. Authorized AFS distributors are also located in many of the world's

industrial and Aerospace centers, where they provide a ready source of AFS fasteners, installation tools, tool parts, and application assistance.

## Alcoa Fastening Systems world-wide locations:

### Americas

#### **Alcoa Fastening Systems**

##### Aerospace Products

##### Tucson Operations

3724 East Columbia  
Tucson, AZ 85714  
800-234-4825  
520-747-9898  
FAX: 520-748-2142

#### **Alcoa Fastening Systems**

##### Aerospace Products

##### Carson Operations

PO Box 5268  
900 Watson Center Rd.  
Carson, CA 90749  
800-421-1459  
310-830-8200  
FAX: 310-830-1436

#### **Alcoa Fastening Systems**

##### Commercial Products

##### Waco Operations

PO Box 8117  
8001 Imperial Drive  
Waco, TX 76714-8117  
800-388-4825  
254-776-2000  
FAX: 254-751-5259

#### **Alcoa Fastening Systems**

##### Commercial Products

##### Kingston Operations

1 Corporate Drive  
Kingston, NY 12401  
800-431-3091  
845-331-7300  
FAX: 845-334-7333  
www.hucktools.com

#### **Alcoa Fastening Systems**

##### Commercial Products

##### Canada Operations

6150 Kennedy Road, Unit 10  
Mississauga, Ontario L5T2J4  
Canada  
905-564-4825  
FAX: 905-564-1963

#### **Alcoa Fastening Systems**

##### Commercial Products

##### Latin America Operations

Avenida Parque Lira. 79-402  
Tacubaya Mexico, D.F.  
C.P. 11850  
FAX: 525-515-1776  
TELEX: 1173530 LUKSME

### Far East

#### **Alcoa Fastening Systems**

##### Commercial Products

##### Australia Operations

14 Viewtech Place  
Rowville, Victoria  
Australia 3178  
03-764-5500  
Toll Free: 008-335-030  
FAX: 03-764-5510

### Europe

#### **Alcoa Fastening Systems**

##### Commercial Products

##### United Kingdom Operations

Unit C, Stafford Park 7  
Telford, Shropshire  
England TF3 3BQ  
01952-290011  
FAX: 0952-290459

#### **Alcoa Fastening Systems**

##### Aerospace Products

##### France Operations

Clos D'Asseville  
BP4  
95450 Us Par Vigny  
France  
33-1-30-27-9500  
FAX: 33-1-34-66-0600

For The Long Haul, The Future of Fastening Technology, The Future of Assembly Technology, The Future of Tooling Technology, and Tools of Productivity are service marks of Huck International. Huck provides technical assistance regarding the use and application of Huck fasteners and tooling.

NOTICE: The information contained in this publication is only for general guidance with regard to properties of the products shown

and/or the means for selecting such products, and is not intended to create any warranty, express, implied, or statutory; all warranties are contained only in Huck's written quotations, acknowledgements, and/or purchase orders. It is recommended that the user secure specific, up-to-date data and information regarding each application and/or use of such products.

HWB898 1003-5M



# Alcoa Fastening Systems



One Great Connection<sup>SM</sup>